

ROOFS WITH PHOTOVOLTAIC SYSTEMS

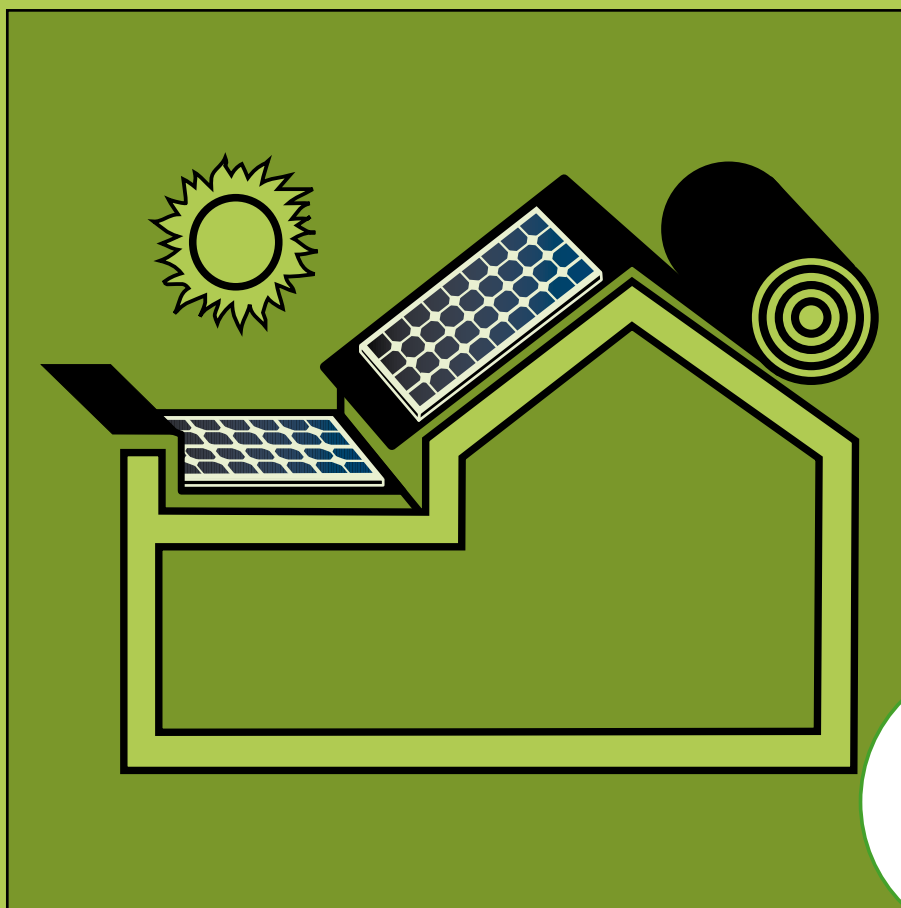

Choosing the layers and the connection methods used for photovoltaic systems not integrated with waterproofing in old and new roofs

Roofs are especially likely to be used in the production of electricity from solar energy. This is particularly true for flat roofs, as it is easier to adjust the system so that it is in the most suitable position for optimal photovoltaic panel performance.

A photovoltaic system should last for at least 20 years, and after this time its renovation may be limited simply to replacing the photovoltaic module, retaining the metal frame to which it is secured which, in turn, can be fixed to the roof so that it spans the waterproofing layers. For this reason, in the case of new roofs, it is important to provide a double-layer system and apply long-life membranes certified with the DVT-Agrément of the I.T.C. (formerly I.C.I.T.E.), such as the following membranes: PROTEADUO TRIARMATO and MINERAL PROTEADUO TRIARMATO, HELASTA POLYESTER and MINERAL HELASTA POLYESTER, FLEXTER FLEX TESTUDO SPUNBOND POLYESTER and MINERAL FLEXTER FLEX TESTUDO SPUNBOND POLYESTER.

Equally, for old roofs which are intended to be used for this purpose, after a thorough evaluation of the existing membrane (which may have deteriorated or may be nearing the end of its guarantee period), you can opt for the complete refacing of the membrane or, in the case of bituminous membranes, simple renovation through the "integral overlapping" of the existing waterproofing material.

After an overview of the different types of photovoltaic panels, where fixings which span the waterproofing materials are anticipated, you will find a range of devices suggested for securing the waterproof membrane to the panel supports and information relating to the most effective strategies in utilising photovoltaic module output.

The same applies to pitched roofs with a MINERAL FLEXTER FLEX TESTUDO SPUNBOND POLYESTER membrane under the tiles, and to pitched roofs with DIFOBAR breathable sheets under the tiles.

The following information does not cover thin film photovoltaic panels integrated into the waterproof membrane and, in conformity with the recommendations made by ENEA (organisation for new technology concerning energy and the environment) to the fullest possible extent, the photovoltaic panel on the roof should not interfere with the waterproofing and insulation materials.

The architecture used in sustainable building is not limited to the design of a “conserving” shell in terms of energy: current design research is intended to make the building shell perform an “active” energy role through the application of solar energy collectors and photovoltaic systems for solar energy production. The European Directive promoting the use of renewable energy sources (Directive 2001/77/EC), assimilated in Italy through Law Decree 387 of 2003 and followed up by subsequent implementation regulations, introduced Conto Energia, a working account scheme incentivising the production of electricity using solar energy from photovoltaic systems connected to the electricity mains on a permanent basis. Italy is one of the sunniest European countries, especially in the Southern regions, but its photovoltaic industry is one of the least developed in the world.

It is estimated that in Italy, using current technology, a photovoltaic system is capable of generating approximately 1150 kWh per year for each kWp of photovoltaic modules installed, a value which gradually rises to 1500 kWh as you move southwards. Germany, in spite of its less favourable geographical position, is particularly advanced in its production of electricity from solar energy; however, for each kWp of photovoltaic modules installed, just 600 kWh/kWp is produced per year.

Italy's favourable climatic situation allows the beneficiary to recoup all outlay costs within the space of ten years, and to make approximately the same amount in the following ten years. In the south, the situation improves even further, as the investment tends to be repaid within approximately 8 years. Roofs on top of buildings, especially non-walkable flat roofs with a visible waterproof covering, are

GBC ITALIA (Green Building Council) AND LEED CERTIFICATION



GBC Italia, to which INDEX belongs, has the task of using the guidelines common to everyone in the **LEED** international community to develop the characteristics of the **LEED Italia** system, which must take into consideration the specific climatic, building and legislative conditions in Italy. **LEED** opts for a view of sustainability by making the most of all opportunities to reduce the various kinds of environmental impacts and harmful emissions of the buildings being built. The **LEED** (Leadership in Energy and Environmental Design) standards are parameters for *sustainable building* developed in the USA and applied in 40 countries throughout the world. They indicate the requirements for eco-compatible buildings, able to “work” sustainably and self-sufficiently energy-wise. It is essentially a rating system for the development of “green” buildings.

LEED is a certification, which may be obtained on a voluntary basis, where the designer actually deals with collecting data for the assessment. The system is based on the award of credits for each of the requirements that characterise the sustainability of the building.

The certification level achieved comes from the sum of the credits.

The assessment criteria used by **LEED** (2009 version) are grouped into six categories (+1 only valid in the USA), which envisage one or more compulsory prerequisites and a number of environmental performances that contribute to the building's final score:

- Sustainable sites (1 prerequisite, 26 points)
- Efficient water consumption (1 prerequisite, 10 points)
- Energy and atmosphere (3 prerequisites, 35 points)
- Materials and resources (1 prerequisite, 14 points)
- Indoor environmental quality (2 prerequisites, 15 points)
- Innovation and design process (6 points)
- Regional priority (4 points) only applicable in the USA

There are 4 rating levels:

- Certified: between 40 and 49 points
- Silver: between 50 and 59 points
- Gold: between 60 and 79 points
- Platinum: more than 80 points

The following point in the **LEED** regulations includes the solar reflectance index:

- **SS Credit 7.2: Heat Island Effect - Roof** SRI (solar reflectance index) limits of the roofing materials

unused surfaces which could conveniently be utilised for the production of electricity from solar energy by means of a photovoltaic solar

panel system, in compliance with sustainable building criteria.

USEFUL INFORMATION REGARDING PHOTOVOLTAIC PANELS INSTALLED ON A ROOF

Orientation and slope

The ideal orientation and slope for photovoltaic panels is facing south, at approx. 30°; however, satisfactory results can also be achieved with south-east and south-west facing panels, at sloping angles of 20° and 40°.

On a flat surface, output is reduced by approximately 10% in relation to the figure achieved using the ideal slope.

System with directed modules

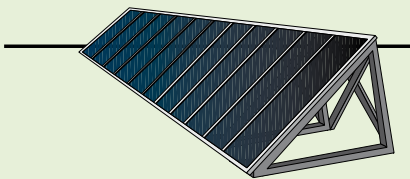

System with flat, rigid modules

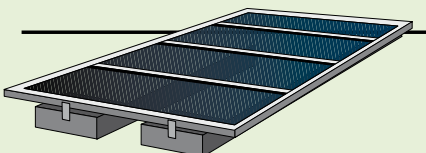

Output and surfaces

Photovoltaic panels currently on the market use various technologies, offering different performance levels. Using high-output modules to achieve a given power value only requires a small surface area, saving space and making it easier to position the panels in the sunniest areas on the roof, avoiding shady spots.

The mass per unit area of a photovoltaic system

The weight per square metre of the photovoltaic system is particularly important; it must be aligned with the extra load capacity of the roof. The load not only depends on the unit weight of the panel, but also on the roof installation method used.

The impact of panels secured by means of a ballast (in order to avoid puncturing the waterproof covering) is linked to the amount of wind in the area and the geometry of the roof, and is greater than the impact of systems which are mechanically fixed to the support (the average weight is 40-50 kg/m²).

However, innovative tubular photovoltaic modules are available which do not require ballasts or fixings; these can withstand winds of around 208 km/h and weigh 16 kg/m².

Ballasted system

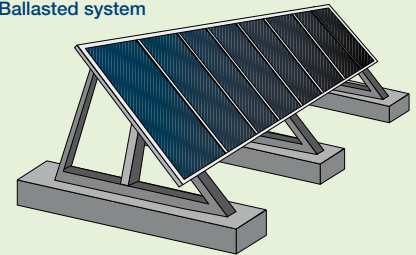

System fixed mechanically

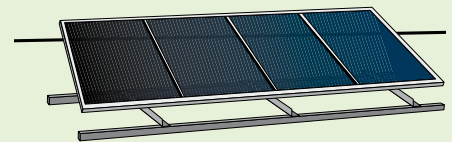

System with supported interlocking modules

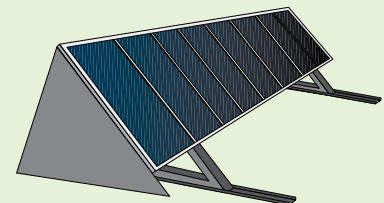

Supported tubular system

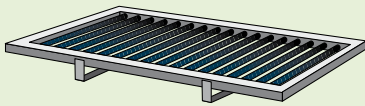

The wind and air do not catch the tubes

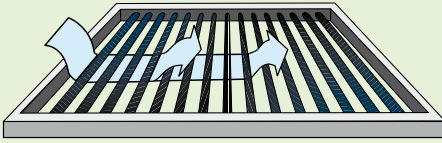

Temperature

The declared performance of the photovoltaic panels is for a temperature of 25°C, but you should bear in mind that in crystalline silicon panels this drops as the temperature increases (by 0.3 - 0.4% for every °C); a black surface on the roof can reach temperatures of over 70°C. Ventilation at the rear of the panel and a reduced surface temperature for the roof on which the system is installed are therefore of great importance for optimum performance.

Tubular models and sloping panels are ventilated at the rear

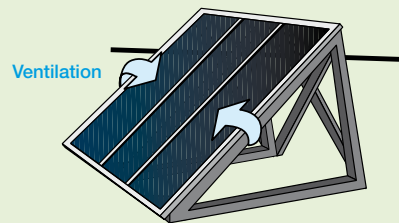
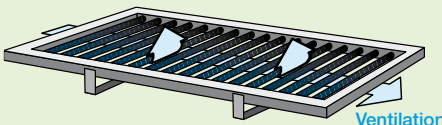

Cleaning the panel

Panel efficiency is closely linked to the regular cleaning of its surface. Only glass-coated panels offer efficient cleaning but the deposits left by standing water must be removed, otherwise the panel will not produce any energy.

This is of such importance that panels are now being made without aluminium frames, to prevent even the smallest amount of water from collecting on the panel.

Solar radiation

Overall solar radiation reaching the photovoltaic module can be split into three components: direct radiation, diffused radiation and reflected radiation.

Direct radiation is the segment of radiation directly reaching the photovoltaic module, for example on days when the sky is clear.

Diffused radiation is a segment of direct radiation which is diffused as it passes through clouds and particles in the atmosphere. This is why the panel still produces energy - albeit on a lesser scale - when the sky is overcast.

Finally, reflected radiation is the segment of solar radiation reflected towards the panel by

the surrounding environment, for example when there is snow on the roof. Reflected radiation therefore depends on the materials surrounding the photovoltaic field and, with suitable devices, can increase performance in traditional panels. It can become especially important for panels which use more than the surface facing the sun to produce energy, such as the tubular models.

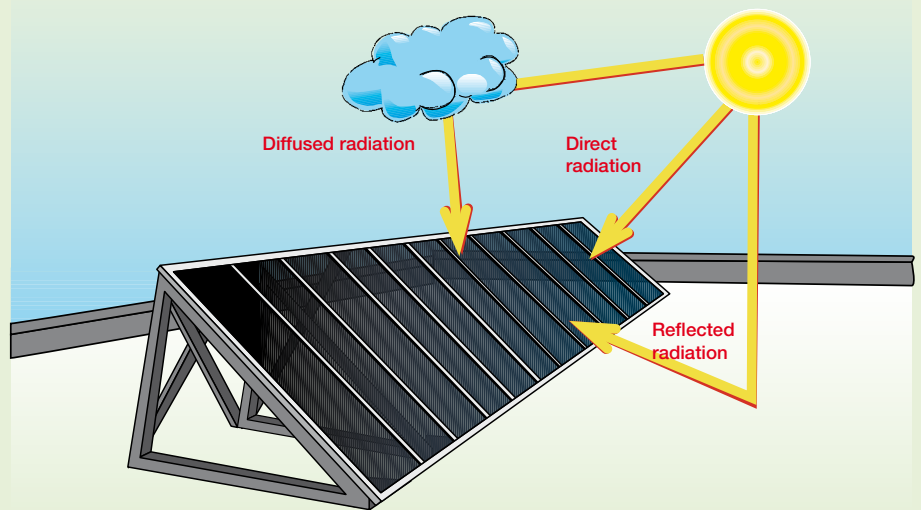

INFLUENCE OF THE WATERPROOF COVERING ON THE PHOTOVOLTAIC SYSTEM INSTALLED ON THE ROOF

In the previous chapter we saw how temperature and reflected radiation can influence photovoltaic system output. Both are determined by the surface colour of the waterproof covering on which the panel is mounted.

Over 90% of roofs are dark coloured and the surface directly under the solar radiation reaches temperatures of around 80°C, with a negative impact on photovoltaic panel output, which lessens as the temperature increases.

Increasing roof surface reflectance by means of special treatments applied to the surface of the waterproof covering offers the dual benefit of reducing the temperature to a value as low as 40°C while raising the albedo, the fraction of incident radiation reflected by the roof surface, to increase photovoltaic system output.

INDEX systems used to increase roof reflectance

The choice of colour for the uppermost layer of the waterproof covering (which ideally should have mineral self-protection (MINERAL) provided by slate granules as this is the most durable option and is not subject to the problems suffered by membranes with metallic self-protection) is the first strategy applied to increase solar radiation reflectance. The table below lists the temperatures reached in summer by various waterproof covering finishes; this clearly illustrates how a white slate membrane reduces the temperature of the roof.

Due to their shiny surface, self-protected metal foil membranes offer high solar reflectance but low infrared emissivity; once oxidised, IR emissivity increases but solar reflectance is reduced. Aluminium paints only offer modest longevity.

Temperature levels reached by the waterproof covering with different surface finishes exposed in the same conditions to summer solar radiation	
Surface finish	Max. Temp.
Black bituminous membrane	78°C
Grey slate membrane	74°C
White slate membrane	70°C
Painted aluminium bituminous membrane	67°C
Self-protected membrane with copper foil	60°C
Self-protected membrane with aluminium foil	55°C

THE NEW INDEX SOLUTIONS

Slate membranes painted with MINERAL REFLEX WHITE

The **MINERAL REFLEX WHITE** treatment for membranes in the MINERAL range is based on the application of a special high saturation and luminosity white mineral self-protection which allows the creation of roofs with high solar reflectance levels and extremely high thermal emissivity levels.

A dark roof will have very low solar reflectance levels, and during the day will absorb a lot of heat which is not effectively dispersed overnight, even if it has high infrared emissivity. A roof with aluminium paint offers good solar reflectance, which reduces heat absorption during the day but slows down overnight heat dispersal due to its low IR emissivity.

A **MINERAL REFLEX WHITE** roof offers good daytime reflectance as well as high overnight emission, meaning heat absorption is lower and resulting in beneficial effects in terms of the energy consumed in summertime by air conditioning inside the building. The **MINERAL REFLEX WHITE** treatment pro-

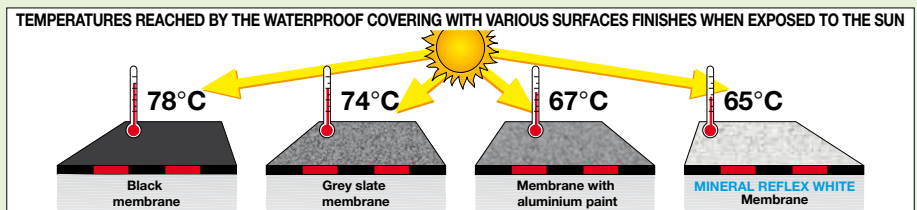
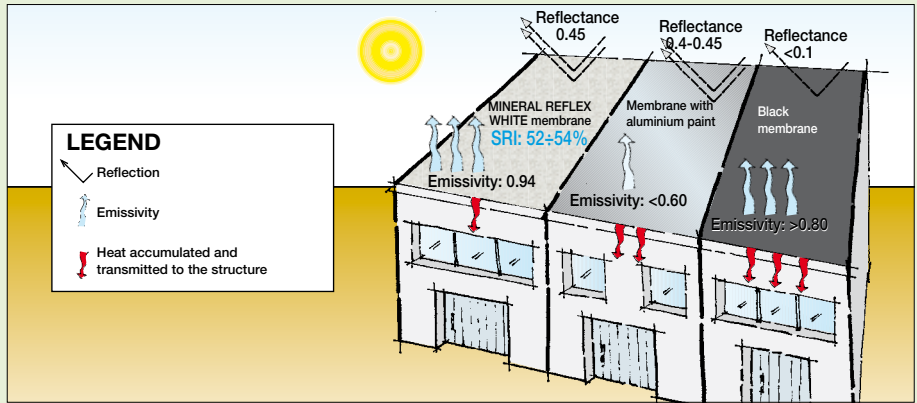

MINERAL REFLEX WHITE FLEXTER TESTUDO

Reflectance R=45%

Emissivity E=94%

Solar Reflectance Index SRI* = 52 - 54%

* SRI depending on wind speed: low=52%, medium=53% and high=54%.

duces a further environmental benefit as it reduces urban overheating.

In compliance with Green Building Council criteria, the membrane is therefore capable of satisfying the SRI>29 requirement corresponding to **LEED** Credits:

- SS Credit 7.1. Heat island effect: Underground car park roofs
- SS Credit 7.2. Heat island effect: Roofs

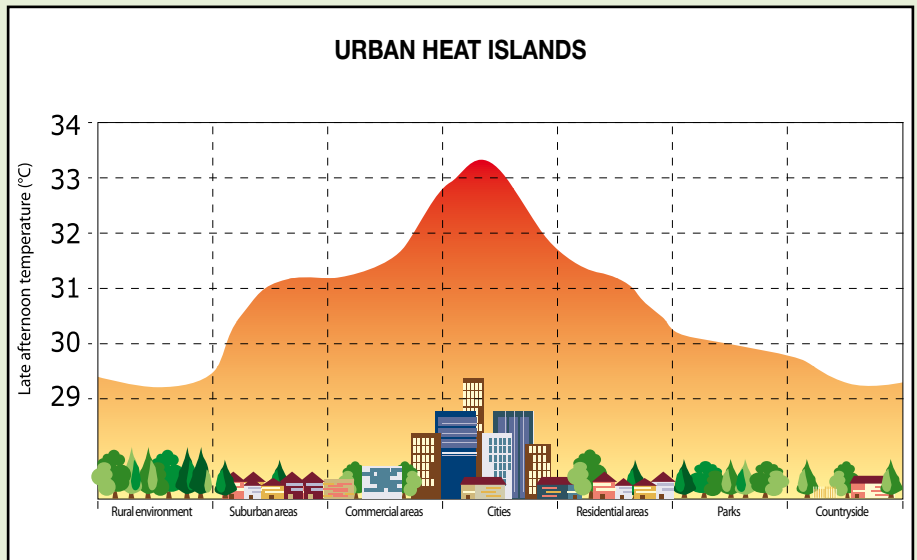

WHITE REFLEX paint

The INDEX Research and Development department has developed **WHITE REFLEX**, a new water-based paint which, when applied to waterproof membranes on roofs with visible coverings, reduces their daytime temperature and allows rapid cooling at night; this lessens heat transmission into living spaces and

therefore lowers the amount of energy consumed in summertime by air conditioning while reducing urban overheating.

WHITE REFLEX increases both the reflectance and the emissivity of surfaces to which it is applied.

WHITE REFLEX paint, with its special white pigment, offers temperature reduction which

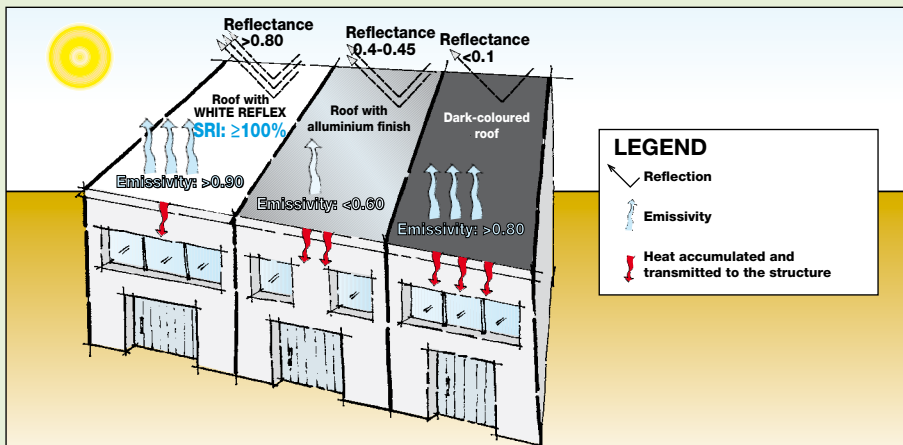

Temperature levels reached by the waterproof covering with different surface finishes exposed in the same conditions to summer solar radiation

Surface finish	Max. Temp.
Black bituminous membrane	78°C
Grey slate membrane	74°C
White slate membrane	70°C
Painted aluminium bituminous membrane	67°C
MINERAL REFLEX WHITE membrane	65°C
Self-protected membrane with copper foil	55°C
Self-protected membrane with aluminium foil	55°C
Bituminous membrane with WHITE REFLEX paint	42°C

outweighs that of metal self-protected membranes and, as you can see from the table above, is even more effective than the **MINERAL REFLEX WHITE** treatment.

REFLECTANCE		EMISSIVITY	
Black bituminous membrane	<0.10	Black bituminous membrane	>0.80
Painted aluminium membrane	0.40-0.45	Painted aluminium membrane	<0.60
Bituminous membrane with WHITE REFLEX paint	>0.80	Bituminous membrane with WHITE REFLEX paint	>0.90



WHITE REFLEX
Solar Reflectance Index
SRI>100

In compliance with Green Building Council criteria, the **WHITE REFLEX** paint used on the slate membrane helps to satisfy the following **LEED** criteria:



LEED - EA Credit 1: Optimise Energy Performance

Cool roofs with **WHITE REFLEX** paint can be modelled in the design proposal to demonstrate the impact in the reduction of free heat contributions. If the suggested roof has an initial reflectance of at least 0.70 and an emissivity of at least 0.75, the design proposal may use a modelled reflectance of 0.45, thus taking account of its degradation, as opposed to the default value of 0.30 modelled on the reference building.

ROOF WITH WHITE REFLEX	
Reflectance	>0.80
Emissivity	>0.90

LEED - SS Credit 7.2. Heat Island Effect - Roofs

Roofs painted with **WHITE REFLEX** reduce the "heat island" effect (differences in heat gradient between urban areas and green spaces) and minimise impact on the surrounding microclimate, as well as human and animal habitats.

Option 1: requires roofing materials with a Solar Reflectance Index (SRI) equal to or greater than the values indicated in the table below for a minimum of 75% of the roof surface.

Gently sloping pitched roofs ≤2:12(9.5°-16.7%)	LEED standard SRI≥78
Steep pitched roofs >2:12(9.5°-16.7%)	LEED standard SRI≥78
Roof with WHITE REFLEX	SRI≥100

Option 3: Install high albedo and vegetated roof surfaces that together meet the following criteria: (Area of roof meeting minimum SRI/0.75) + (Area of vegetated roof/0.5) ≥ Total roof area

LEED - EA Credit 2: On-Site Renewable Energy

WHITE REFLEX increases the output of photovoltaic solar panels, one of the systems used in the on-site production of energy from renewable sources, permitted in point EA 2 and used to balance the energy consumption of the building (the estimated rise is 4 - 10%, tests are currently being conducted on roof-installed systems).

The application of a **WHITE REFLEX** paint, which can maintain the temperature of the waterproof covering at a value around 40°C, reduces the temperature of the rigid crystalline silicon photovoltaic panel by 10 - 20°C, increasing its output by 3 - 8%. Photovoltaic panel output rises as the environmental luminosity increases.

The **WHITE REFLEX** reflective paint increases albedo, improving photovoltaic panel output.

It is estimated that the combination of these two effects increases the output of photovoltaic panels with traditional concentration (consisting of crystalline or polycrystalline cells) by around 4 - 10%.

To demonstrate and prove this statement,



INDEX has been conducting a series of on-site tests and laboratory trials since 2007, in collaboration with the University of Modena and Reggio Emilia.

In addition to waterproofing tests on the most varied application surfaces, specific examinations have been conducted to assess potential increases in energy production which can be attributed to the presence of a reflective support treated with **WHITE REFLEX**.

Since April (the month in which **WHITE REFLEX** was applied), the energy production levels of a photovoltaic system with crystalline silicon cells have been monitored.

This is located on a roof measuring approx. 700 m² so that a comparison can be made between before and after the reflective cooling treatment is applied using **WHITE REFLEX** paint.



YEAR 2009	ENERGY PRODUCED [Watts]	SUN [days]	RAIN [days]	ENERGY / day of SUN [Watts / day of SUN]
MAY	19341.5	24.5	6.5	789.45
JUNE	18709.7	22	8	850.44
JULY	25294.7	28.5	2.5	887.53
AUGUST	21406.3	27.5	3.5	781.68
SEPTEMBER	15953.1	20	4	613.58
Total	100795.3	128.5	34.5	784.40

YEAR 2010	ENERGY PRODUCED [Watts]	SUN [days]	RAIN [days]	ENERGY / day of SUN [Watts / day of SUN]
MAY	17855.6	18.5	14.5	1070.04
JUNE	22727.5	25.5	4.5	891.27
JULY	25065.8	28.5	2.5	879.50
AUGUST	20814.4	25.5	5.5	816.25
SEPTEMBER	14076.8	22	8	639.65
Total	100340.1	118	35	850.34

The above output comparison relates to a 5-month period (May to September) in 2009 (untreated roof with a visible black bituminous covering) and in 2010 (after treatment). To obtain a rough - but nonetheless indicative - evaluation, the data was compared while taking account of sunshine hours by consulting meteorological tables for the municipality of San Giovanni in Marignano

(RN). From the calculations performed, discounting the days affected by persistent rain and assuming production was halved on days when the weather was stormy, it was immediately evident that despite a marked increase in rainfall (mostly occurring in May 2010), the system maintained a constant energy production level over the 5-month

period. The final column, listing the data most relevant to the original purpose of the test, energy production (in the form of suggested energy per sunny day), contains significantly increased values and corresponds to a figure of around 8%.

In conclusion, a commercial assessment may now also be conducted in order to quantify the financial benefit of using extremely high solar reflectance **WHITE REFLEX** paint.

Once the necessary conditions for the approximation of sampling data have been met (the periods and sunlight intensity are not yet firmly established) and the deterioration and loss of output for the system have been calculated (the manufacturers indicate that any decline in output takes place very early on within the operating period), and taking account of the potentially saleable energy produced as well as the amount not required by the mains supply user, the system would have yielded an excess of approximately 8400 Watts, which is almost enough to cover the cost of purchasing and applying the paint.

In short, we could say that the work pays for itself over the course of a year and creates "wealth" in following years.

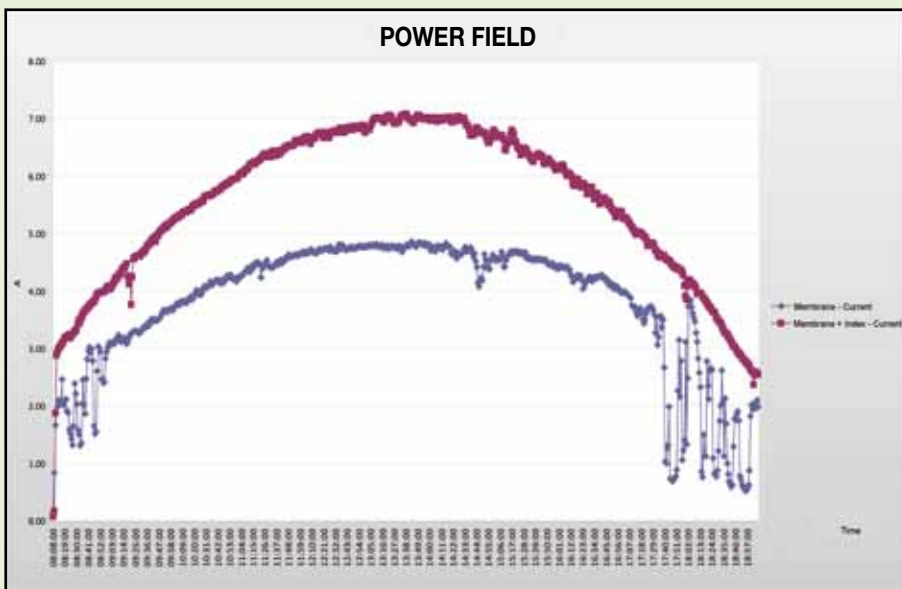

In addition to the systems equipped with crystalline silicon (used in approximately 85% of applications up to this point), other types of photovoltaic panels are now becoming more widespread in Italy.

One of the most interesting is an American-produced type, a revolutionary product due to its easy installation and maintenance procedures, which does not require the use of mechanical fixing elements or ballasts on the roof. These systems have cylindrical elements in CIGS (copper, indium, gallium, diselenide), capable of capturing both direct and reflected solar radiation from the roof treated with **WHITE REFLEX**.

The increases in energy production should be even more consistent than the results recorded in the previous test.

In the summer of 2009 (application took place on 29th June) a test was performed which provided some particularly interesting results.

On the date of the first on-site inspection, the cylindrical cell system located on a small roof (approx. 100 m²) with a bituminous surface covering self-protected with green slate granules was producing energy at a deficit of 36% in comparison with the nominally anticipated figure.



The system dysfunction was due to the bad solar reflectance values of the roof; the subsequent application of **WHITE REFLEX** paint would have demonstrated this hypothesis.

1 month after application, the energy production data was retrieved and, as illustrated by the graph (see previous page), an increase of 30% was recorded in the current field (and therefore the power field) produced.

The other graph (adjacent to this paragraph) corresponds to the energy produced by the system over the course of one sunny day, before and after treatment with **WHITE REFLEX**; it shows a significant improvement, especially in the hours in which albedo is at its worst (early morning and sunset).



BEFORE
After application the effect of the paint could be detected immediately, albeit in a generalised manner, by using a solarimeter to measure solar radiation. Solar reflectance increased roughly sevenfold.

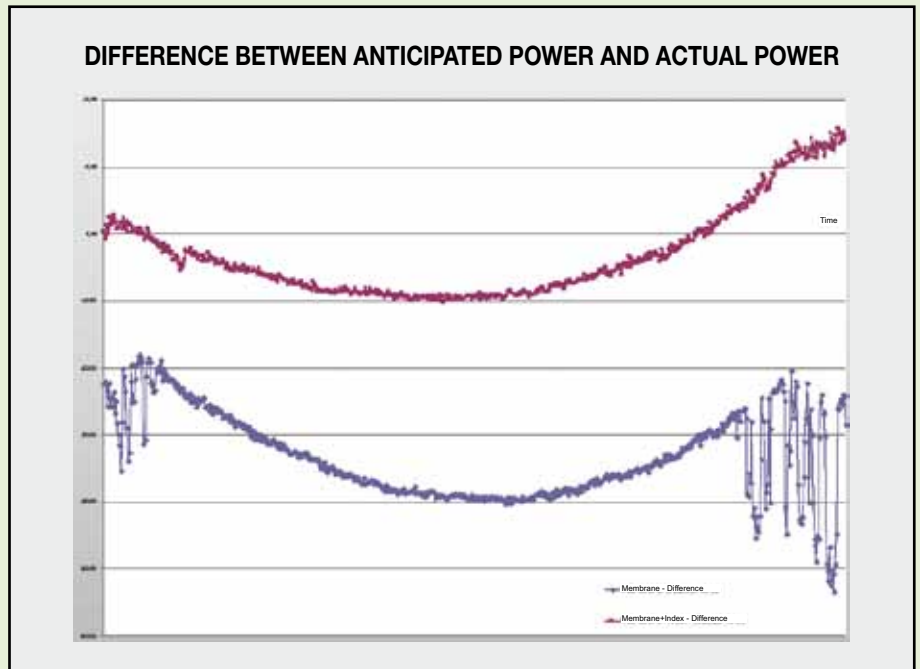

In conclusion, although the experiment is not yet complete, a roof with high solar reflectance is entirely necessary for cylindrical cell systems and **WHITE REFLEX** paint, thanks to its considerable application flexibility (it can be used on almost all supports), should be

considered as one of the most viable solutions.

SOME RECOMMENDATIONS extracted from the “L’ENERGIA FOTOVOLTAICA” (PHOTOVOLTAIC ENERGY) publication by ENEA

Creating a photovoltaic system is not too complicated, but it is a job which should be carried out by specialists. It is nevertheless useful to familiarise yourself with a few rules which should be observed in the design and application phases.

The support structures should be constructed to last at least as long as the system itself, i.e. 25-30 years, and should be installed so as to allow easy access to modules for cleaning and replacement, and to electric junction boxes for inspection and maintenance. They must also be entirely resistant to corrosion and wind.

Photovoltaic generators installed on roofs must not interfere with the waterproofing and insulation of the surfaces; in some cases it may be necessary to create fixed or mobile walkways.

A gap must be left between modules, from a minimum of 5 mm for generators installed in parallel and near other fixed surfaces, up to 5 cm for generators which may be subjected to high wind pressures.

In the case of roof- or wall-mounted modules, it is essential that a gap of 4-6 cm is left between them so as to guarantee sufficient air circulation and therefore effective cooling of the surface on which the module is installed.

The interconnecting electricity cables and junction boxes must be suitably sized, conform to electrical regulations and guarantee the specified insulation, protection and waterproofing classes as required.

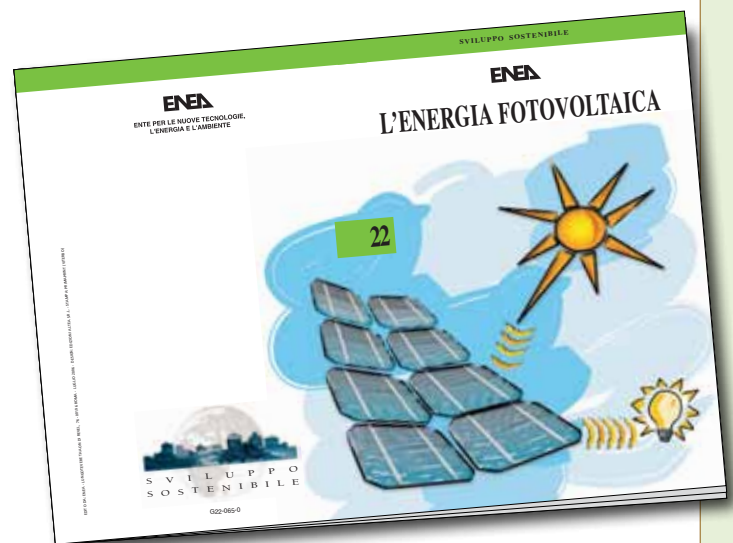

WATERPROOFING AND THERMAL INSULATION

NEW FLAT ROOFS OR COMPLETE REFACING PROJECTS

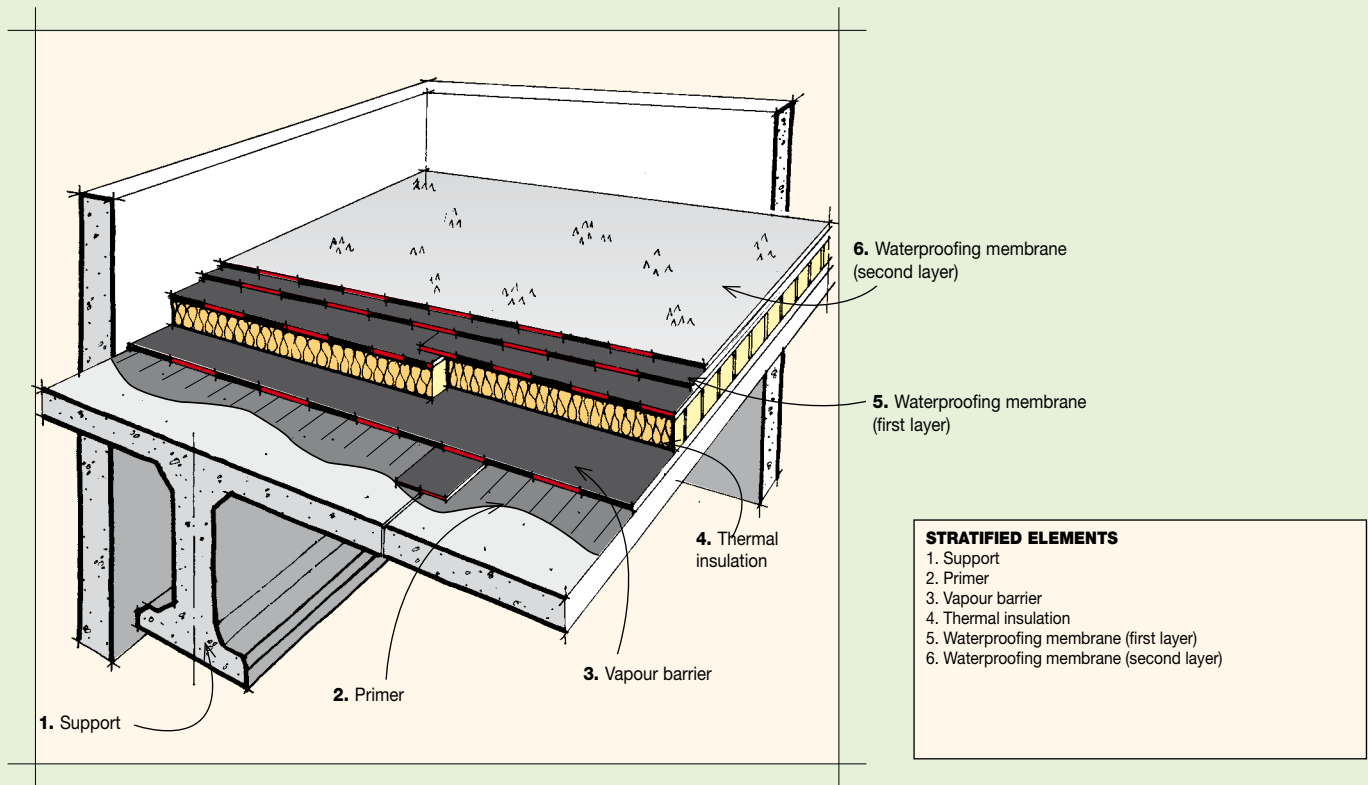

PRIMER

The primer penetrates into the pores of concrete surfaces, stops dust and has the job of promoting adhesion on the surfaces to which the membranes must be stuck. INDEVER is a traditional solvent-based bituminous primer; the ECOVER water-based primer is more innovative

and offers a reduced environmental impact. The whole surface to be covered and the vertical parts onto which the waterproof layer must be stuck are painted with a coat of about 300 g/m² INDEVER adhesion bituminous primer, a solution based on oxidised bitumen, additives and

solvents, with solid content (UNI EN ISO 3251) of 40% and viscosity (UNI EN ISO 2431) of 12-17 s, or ECOVER, a water-based bituminous emulsion with a solid content (UNI EN ISO 3251) of 37% using 250-400 g/m².

VAPOUR BARRIER

For a roof with a covering exposed to the external environment without ballast, the connection of the vapour barrier to the concrete support is of particular importance.

To oppose the force of the wind and to guarantee the dimensional stability of the stratified elements subject to heat variations, except for in special cases, the connection must be made with total adhesion.

To prevent the formation of bubbles on the vapour barrier generated by concrete supports that are still damp, the vapour barrier + insulation + 1 layer of the covering should all be laid at the same time.

Depending on the different situations and requirements, various technological solutions are identified for the vapour barrier.

	Traditional	Innovative cold-bonded double-sided adhesive (with cold bonding of the insulation incorporated)	Innovative heat-bonded (with heat bonding of the insulation incorporated)
Vapour barrier on roofs of rooms with low humidity (relative humidity <80% at 20°C)	case A DEFEND - 3 mm heat-bonded adhesive under stuck insulation (*)	case C SELTENE BV BIADESIVO POL. SELTENE BV BIADESIVO/V cold-bonded adhesive under stuck insulation (*) (²)	case E TECTENE BV STRIP/V PROMINENT/V heat-bonded adhesive under stuck insulation (³)
Vapour barrier on roofs of rooms with high humidity (relative humidity ≥80% at 20°C)	case B DEFEND ALU POL. - 3 mm heat-bonded adhesive under stuck insulation (*)	case D SELTENE BV BIADESIVO ALU POLYESTER cold-bonded adhesive under stuck insulation (*) (²)	case F TECTENE BV STRIP ALU POL. PROMINENT ALU POL. heat-bonded adhesive under stuck insulation (³)
Special case of draining vapour barrier on roofs of rooms with very high humidity			case G DIFFUSER ALU POL. heat-bonded semi-adhesive + "case A" or "case E"

(*) System to be used for surface areas of <500 m²
 (¹) Insulation stuck with molten oxidised bitumen
 (²) Insulation cold-bonded onto the upper self-adhesive face of the vapour barrier
 (³) Insulation stuck by heat bonding of the strips or the heat-adhesive embossings on the upper face of the vapour barrier
A; B. On DEFEND and DEFEND ALU POLYESTER heat-resistant insulating panels and THERMOBASE PUR and THERMOBASE FR are chosen.
C; D. On SELTENE BV BIADESIVO polystyrene or polyurethane panels can be stuck, and THERMOBASE PSE, THERMOBASE PSE/EX and THERMOBASE PUR.
E; F. Heat bonding on PROMINENT is reserved for heat-resistant thermal insulation and THERMOBASE PUR, whereas on TECTENE BV STRIP polystyrene and polyurethane panels can be stuck, and THERMOBASE PSE, THERMOBASE PSE/EX and THERMOBASE PUR using suitably trained labour.

THERMAL INSULATION

This is required for containing energy consumption and limiting any dilations of the load-bearing structure; it also prevents internal condensation of water vapour on cold walls. Either fibrous or cellular, the most common insulators are: glass or rock mineral fibre panels, expanded polyurethane or polystyrene panels, perlite agglomerates and cellulose fibres, cork, etc. INDEX produces the THERMOBASE insulation in rolls, consisting of strips of insulating material already stuck onto a polymer-bitumen membrane, a product that meets the specifications of *sustainable building* as membrane/insulation coupling in the factory reduces the laying operations on the roof and the consequent emission of fumes, odours and noise in the surrounding environment. For non-walkable flat roofs with a visible covering underneath the photovoltaic system, types offering greater re-

sistance to compression and the pedestrian traffic required for system maintenance should preferably be used. The insulating materials are produced in different types, densities and dimensions, according to their destination. It is important to choose materials of the type expressly declared by the manufacturer as being suitable for roof insulation, to be stuck and coated with polymer-bitumen membranes and bituminous materials in general. Cellular insulating materials are preferable because, in the event of leaks in the waterproof layer, they absorb less water. Heat-resistant insulating panels (perlite, expanded polyurethane) and THERMOBASE PUR can be stuck with molten oxidised bitumen. For safer laying, reducing the risk of burns and the emission of fumes and odours, the expanded polyurethane panels and THERMOBASE PUR can also be heat-

bonded onto the PROMINENT and TECTENE BV STRIP EP membranes and can be heat-bonded directly to the waterproof covering suggested below. Expanded polystyrene insulating panels can be heat-bonded onto TECTENE BV STRIP EP or cold-bonded onto SELFTENE BV BIADESIVO and then before laying the waterproof layer they must be protected with the self-heat-adhesive membrane in the AUTOTENE BASE series, which is stuck alone onto the polystyrene panel using the heat transmitted from the heat bonding of the waterproof layer above; alternatively, rolls of insulation pre-coupled to a membrane of the THERMOBASE PSE/120 or THERMOBASE PSE/EX type can be used. The insulation must be thick enough to prevent the dew point dropping below the vapour barrier and must comply with current legislation relating to energy containment in buildings.

THERMOBASE PUR/35-V3					
Thickness	20	30	40	50	60
Thermal resistance R(m ² K/W)	0.686	1.025	1.362	1.695	2.029

THERMOBASE PSE/120-V3							
Thickness	20	30	40	50	60	70	80
Thermal resistance R(m ² K/W)	0.494	0.740	0.985	1.217	1.458	1.705	1.947

THERMOBASE PSE/EX-V3					
Thickness	20	25	30	40	50
Thermal resistance R(m ² K/W)		0.838	1.114	1.377	1.650

WATERPROOF COVERING

A roof with a visible covering is the most common and widespread solution for industrial and commercial buildings and is often very large. The visible covering is under more strain as it is exposed to the elements; if located underneath a photovoltaic system which should last for 20 years, it is important to choose long-lasting membranes. The membranes suggested in this publication, from the PROTEADUO, HELASTA and FLEXTER FLEX TESTUDO ranges, are all covered by the Agrément I.T.C.-CNR (formerly I.C.I.T.E.) which certifies their durability and relative constant periodic inspections. Bear in mind that the waterproof covering is a continuous element that almost always covers discontinuous elements; therefore the mechanical resistance and elasticity of the covering also play an important role as a good grip must be guaranteed on concrete laying surfaces where there may be cracks or where the joining lines of prefabricated concrete panels or insulating panels undergo opening and closing cycles generated by temperature differences and can cause fatigue of the covering above, causing the waterproofing to crack. The waterproof covering must offer high mechanical resistance and elasticity and a sufficient resistance to impact and static load, to withstand the strains to which it is subjected. The high fatigue resistance of the materials - which is also high at low temperatures in the case of elastomeric and composite membranes - offers a choice in the connection of the covering to the laying surface in total adhesion. The completely stuck covering is more stable and more resistant to impact and static load, wind and hail stones and, in the event of accidental tearing, not much water passes through. A visible covering is exposed to hail stones and to increase the resistance of exposed coverings it is best:

- to use elastomeric membranes (HELASTA, PROTEADUO TRIARMATO) reinforced with non-woven

polyester fabric laid in a double layer; - to use membranes with a slated finish as the top layer (MINERAL HELASTA, MINERAL PROTEADUO TRIARMATO).

The recommended connection to the laying surface for the visible covering is in total adhesion which, as well as the benefits already stated, combats the phenomenon of reptation which can occur in colder climates on exposed coverings without heavy protection. Temperature variations cause the waterproof covering to constantly contract and relax alternately, leading to a progressive centralisation of the covering which drags the layers connected to it towards the geometric centre of the roof, causing folds and detachments from the corners and edges and from all parts protruding from the covering (chimneys, skylights, etc.) to which it is stuck. Hence the importance of total adhesion between all the layers and the vapour barrier to the concrete support as well as care in performing the detailed operations on the fixed points of the roof (external walls, drains, chimneys, skylights, etc.). Only in the case of visible coverings laid directly onto concrete supports is it recommended to use semi-adhesion as an alternative to total adhesion, in order to prevent the formation of bubbles on the covering due to humidity trapped in damp supports transformed into vapour when they are exposed to the sun; however, in these cases the problem of reptation is almost non-existent or significantly reduced. The recommended membranes are all certified with the Agrément I.T.C.-CNR (formerly I.C.I.T.E.) and, in compliance with relative EC marking, they can only be laid in a single layer 4 mm thick, however, taking the view of increased safety and in relation to the fact that repair work in the event of a fault on the covering is increasingly expensive, it has become common practice to lay a double layer. The systems recommended in this publication are as follows:

- **Double layer on concrete support**
 - VAPORDIFFUSER STRIP/V + HELASTA POL. 4 mm + MIN. PROTEADUO TRIARMATO 4 mm
 - VAPORDIFFUSER STRIP/V + HELASTA POL. 4 mm + MINERAL HELASTA POLYESTER 4 mm
 - VAPORDIFFUSER STRIP/V + FLEXTER FLEX TESTUDO SP. POL. 4 mm + MIN. FLEXTER FLEX TESTUDO SPUNBOND POL. 4 mm
- **Double layer with visible covering on heat-resistant thermal insulation and on THERMOBASE**
 - HELASTA POLYESTER 4 mm + MINERAL PROTEADUO TRIARMATO 4 mm
 - HELASTA POLYESTER 4 mm + MINERAL HELASTA POLYESTER 4 mm
 - FLEXTER FLEX TESTUDO SPUNBOND POLYESTER 4 mm + MINERAL FLEXTER FLEX TESTUDO SPUNBOND POLYESTER 4 mm
- **Double layer with visible covering on non-heat-resistant thermal insulation**
 - AUTOTENE BASE HE/V + HELASTA POL. 4 mm + MINERAL PROTEADUO TRIARMATO 4 mm
 - AUTOTENE BASE HE/V + HELASTA POLYESTER 4 mm + MINERAL HELASTA POLYESTER 4 mm
 - AUTOTENE BASE HE/V + FLEXTER FLEX TESTUDO SPUNBOND POLYESTER 4 mm + MINERAL FLEXTER FLEX TESTUDO SPUNBOND POLYESTER 4 mm

The use of membranes and durable systems certified with Agréments such as those suggested in this document meets the specifications of *sustainable building* as the primary requirement of system durability is fulfilled, hence delaying the repair and/or demolition work timescales implies a lower consumption of raw materials, less energy consumption, less waste production and lower emissions of pollutants and greenhouse gases over time.

Laying surface preparation, other technical solutions and technical details are illustrated in

TECHNICAL SPECIFICATION 2 “Non-walkable flat roof”



WATERPROOFING AND THERMAL INSULATION RENOVATION OF FLAT ROOFS

Before installing a photovoltaic system on an old roof, the condition of the existing waterproof covering must be carefully assessed, in order to identify the necessary repair and restoration work, as well as the type of devices used (if necessary) to secure the system to the roof.

The thermal resistance of the roof must also be checked, and - if required - an assessment carried out as to whether new insulation should be laid or not. The same applies if the insulating layer is waterlogged, because the covering is no longer watertight.

The situation is different if infiltrations have affected a limited and restricted area of the stratified elements. In this case localised work may be enough to restore the insulating layer, by replacing it with a dry one.

There are many variables and it would be impossible to include them all in this publication, which is restricted to identifying the best solutions for the single-layer renovation of a recently applied waterproof covering in good condition.

A waterproof covering "in good condition" is defined as follows:

- completely dry and watertight
- free from folds and large-scale undulations which indicate extensive reptation beginning at the corners and edges of the roof and moving towards its geometric centre
- free from folds where insulating panel join lines occur
- free from creases extending across the entire surface of the covering
- laid no more than 15 years ago

WATERPROOF COVERING

In the case of older waterproofing laid between 15 and 20 years ago which is still completely watertight and has widespread superficial cracks which do not affect the thickness of the covering but remains perfectly flat, dry and free from signs of tension, single-layer renovation can be considered, for application by means of heat-bonded or cold-bonded MASTIPOL adhesive.

SINGLE-LAYER WATERPROOF COVERING

• Single-layer, heat-bonded to old covering

- INDEVER Primer
- MINERAL PROTEADUO TRIARMATO 4 mm
- or
- INDEVER Primer
- MINERAL HELASTA POLYESTER 4 mm
- or
- INDEVER Primer
- MINERAL FLEXTER FLEX TESTUDO SPUNBOND POLYESTER 4 mm

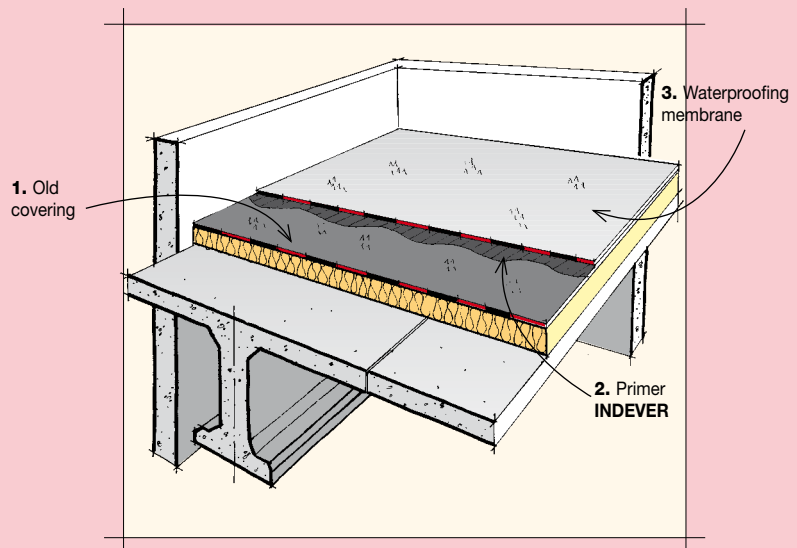

STRATIFIED ELEMENTS

1. Old covering
2. INDEVER primer
3. Waterproofing membrane

• Single-layer, cold-bonded to old covering

- INDEVER Primer
- MASTIPOL adhesive
- MINERAL PROTEADUO TRIARMATO (*) 4 mm
- or
- INDEVER Primer
- MASTIPOL adhesive
- MINERAL HELASTA POLYESTER (*) 4 mm
- or
- INDEVER Primer
- MASTIPOL adhesive
- MINERAL FLEXTER FLEX TESTUDO SPUNBOND POLYESTER TEX (*) 4 mm

(*) For bonding with MASTIPOL, membranes with a Texflamina coated lower face should be used.

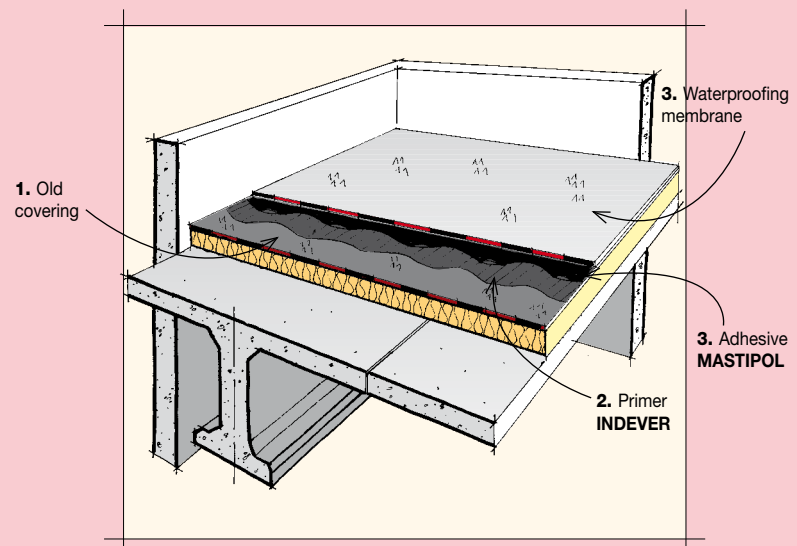

STRATIFIED ELEMENTS

1. Old covering
2. INDEVER primer
3. MASTIPOL adhesive
4. Waterproofing membrane

DOUBLE-LAYER WATERPROOF COVERING

Double-layer renovation, on the other hand, is recommended if the covering can be flattened with a limited amount of work to repair folds, bubbles and undulations, integrating it with the mechanical fixing elements around the edge and at the bottom of the projecting parts; it is also recommended for coverings laid over 20 years ago.

In this case, a distinction needs to be made between completely dry stratified elements onto which the new covering can be stuck in total adhesion mode, and stratified elements still containing a degree of dampness trapped between the layers of the old covering, which could cause bubbles to form if the new covering is stuck on top.

In this instance the new waterproofing will have to be stuck on in semi-adhesion mode.

• Double-layer, adhering to the old covering

- INDEVER Primer
- HELASTA POLYESTER 4 mm + MINERAL PROTEADUO TRIARMATO 4 mm
- or
- INDEVER Primer
- HELASTA POLYESTER 4 mm + MINERAL HELASTA POLYESTER 4 mm
- or
- INDEVER Primer
- FLEXTER FLEX TESTUDO SPUNBOND POLYESTER 4 mm + MINERAL FLEXTER FLEX TESTUDO SPUNBOND POLYESTER 4 mm

STRATIFIED ELEMENTS

1. Old covering
2. INDEVER primer
3. Waterproofing membrane (first layer)
4. Waterproofing membrane (second layer)

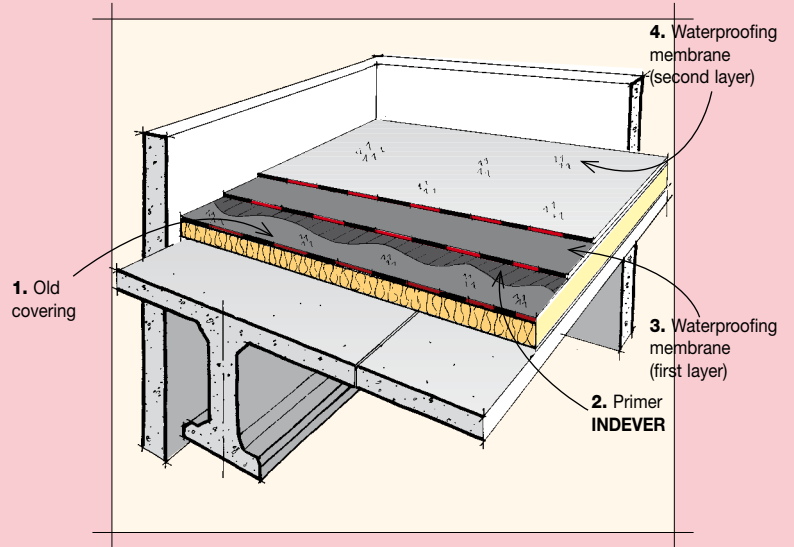

• Double-layer, semi-adhering to the old covering

- VAPORDIFFUSER STRIP/V (*)
- HELASTA POLYESTER 4 mm
- MINERAL PROTEADUO TRIARMATO 4 mm
- or
- VAPORDIFFUSER STRIP/V (*)
- HELASTA POLYESTER 4 mm
- MINERAL HELASTA POLYESTER 4 mm
- or
- VAPORDIFFUSER STRIP/V (*)
- FLEXTER FLEX TESTUDO SPUNBOND POLYESTER 4 mm
- MINERAL FLEXTER FLEX TESTUDO SPUNBOND POLYESTER 4 mm

(*) The use of VAPORDIFFUSER STRIP/V, given the high adhesion level of the adhesive strips distributed on its lower face, means primer does not need to be applied

STRATIFIED ELEMENTS

1. Old covering
2. VAPORDIFFUSER STRIP/V waterproofing membrane
3. Waterproofing membrane (first layer)
4. Waterproofing membrane (second layer)

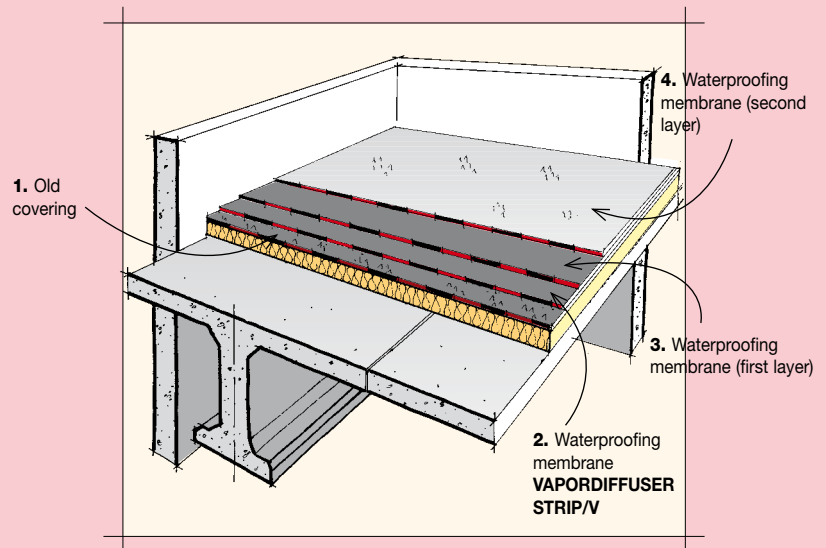

Laying surface preparation, other technical solutions and technical details are illustrated in

TECHNICAL SPECIFICATION 2 “Non-walkable flat roof”



LAYING DETAILS

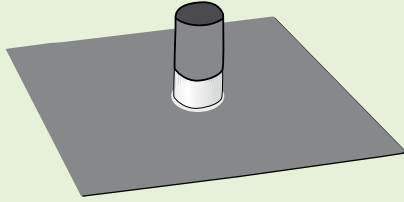

VERTICONNECT is a vertical connection with sleeves, which can be adapted for running cables in waterproofing elements with polymer-bitumen membranes.

It is a safe, flexible and watertight solution for vertical connections, pipes, profiles, consoles, threaded rods, etc. crossing the horizontal surface of a flat roof waterproofed with polymer-bitumen membranes.



2. Application of finishing piece over VERTICONNECT



3. VERTICONNECT fixed on the roof



1. VERTICONNECT application

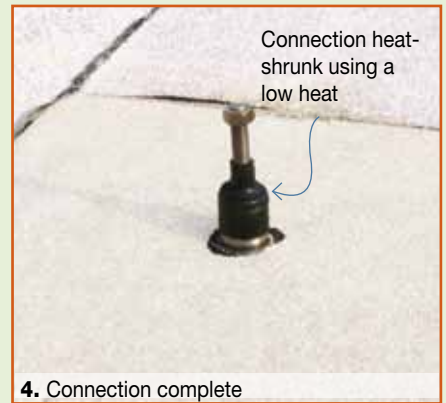

Connection heat-shrunk using a low heat

4. Connection complete

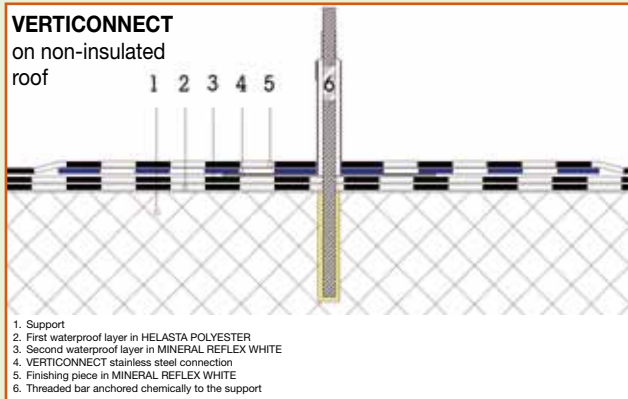

Vertical connections

Fixing the photovoltaic system panels to the covering

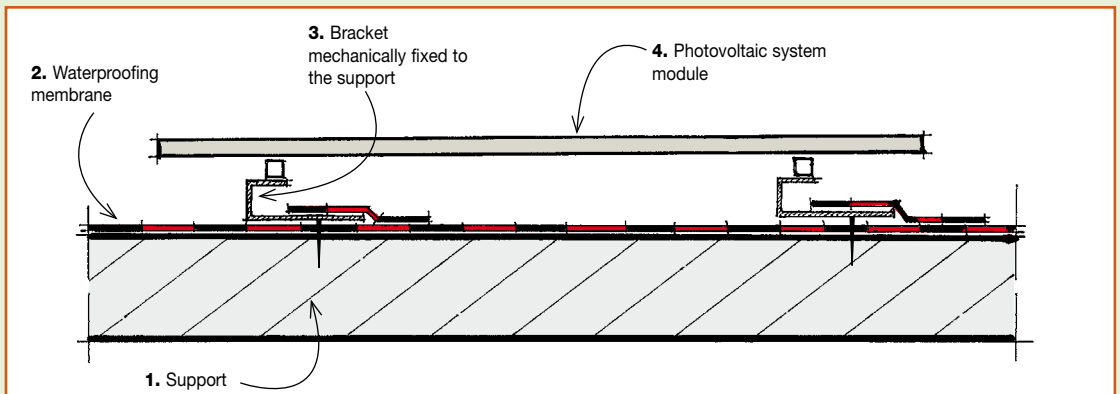

- STRATIFIED ELEMENTS**
1. Support
 2. Waterproofing membrane
 3. Bracket mechanically fixed to the support
 4. Photovoltaic system module

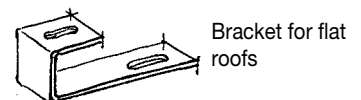

WATERPROOFING AND THERMAL INSULATION UNDER TILES ROOFS WITH AQUIFERS

Laying surface preparation, other technical solutions and technical details are illustrated in

TECHNICAL SPECIFICATION 7 "Under tiles"



Fixing the photovoltaic system panels to tiles with polymer-bitumen waterproofing membranes underneath

- STRATIFIED ELEMENTS**
1. Support
 2. Slate waterproofing membrane
 3. Tiles or slate
 4. Bracket mechanically fixed to the support
 5. Photovoltaic system module

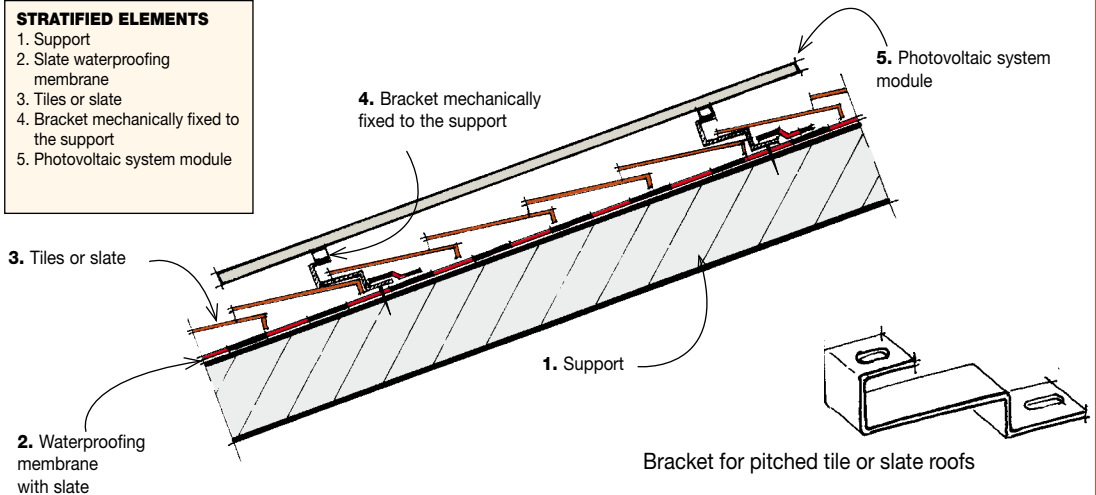

WATERPROOFING AND THERMAL INSULATION UNDER TILES ROOFS WITH AQUIFERS AND BREATHABLE SHEETS

The technical solutions and technical details are illustrated in

GUIDE TO UNDER-TILE PROTECTION WITH BREATHABLE SHEETS



Fixing the photovoltaic system panels to tiles with breathable sheet protection underneath

- STRATIFIED ELEMENTS**
1. Support
 2. DIFOBAR ULTRASINT FORTE under-tile breathable sheet
 3. Wooden strip
 4. Tiles or slate
 5. Bracket mechanically fixed to the wooden strip
 6. Photovoltaic system module

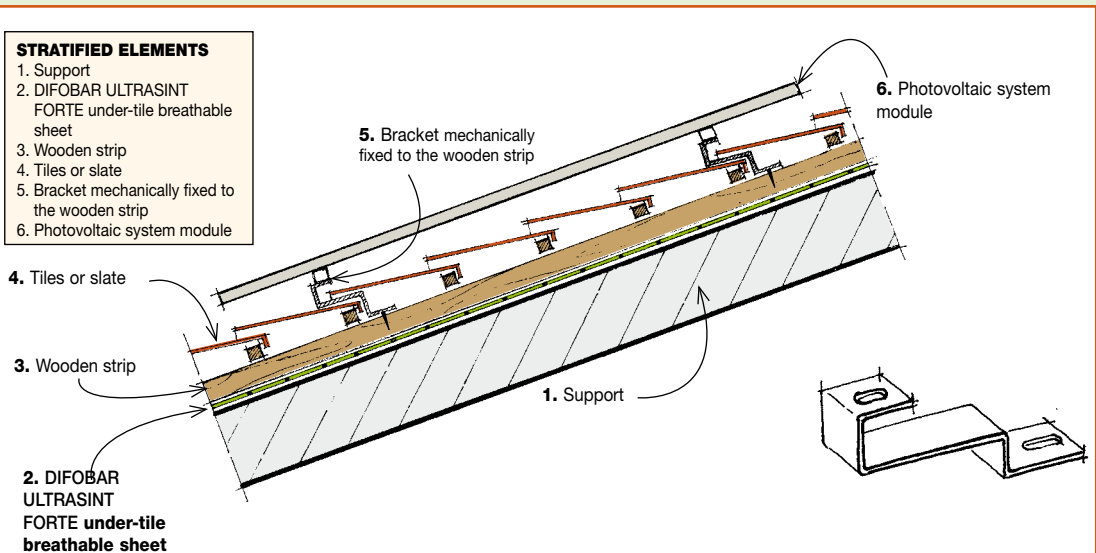

TECHNICAL SPECIFICATIONS

PRIMER

INDEVER

Quick drying adhesion bituminous primer suitable for preparing surfaces for the heat bonding of polymer-bitumen membranes, such as INDEVER, with a base of oxidised bitumen, additives and solvents with solid content (UNI EN ISO 3251) of 40% and cup viscosity of DIN/4 at 23°C (UNI EN ISO 2431) of 12-17 s.

VAPOUR BARRIER

STANDARD VAPOUR BARRIER MEMBRANES

DEFEND ALU POLYESTER

Elastoplastomeric polymer-bitumen vapour barrier membrane, 3 mm thick (EN1849-1), reinforced with aluminium foil coupled to a non-woven composite polyester fabric stabilised with fibreglass, with water vapour permeability (EN 1931) $\mu=1,500,000$, tensile strength (EN 12311-1) L/T of 250/120 N/50 mm and ultimate elongation (EN 12311-1) L/T of 15/20%.

DEFEND/V

Elastoplastomeric polymer-bitumen vapour barrier membrane, 3 mm thick (EN1849-1), reinforced with fibreglass mat, with water vapour permeability (EN 1931) $\mu=100,000$, tensile strength (EN 12311-1) L/T of 300/200 N/50 mm and ultimate elongation (EN 12311-1) L/T of 2/2%.

INNOVATIVE VAPOUR BARRIER MEMBRANES

WITH INCORPORATED ADHESIVE FOR COLD-BONDING OF THE THERMAL INSULATION

SELFTENE BV BIADESIVO ALU POLYESTER

Double-sided adhesive elastomeric polymer-bitumen vapour barrier membrane of 3 kg/m² (EN1849-1), reinforced with aluminium foil, coupled to a non-woven composite polyester fabric stabilised with fibreglass, with water vapour permeability (EN 1931) $\mu=1,500,000$, tensile strength (EN 12311-1) L/T of 250/120 N/50 mm and ultimate elongation (EN 12311-1) L/T of 15/20%.

SELFTENE BV BIADESIVO POLYESTER

Double-sided adhesive elastomeric polymer-bitumen vapour barrier membrane of 3 kg/m² (EN1849-1), reinforced with non-woven composite polyester fabric stabilised with fibreglass, with water vapour permeability (EN 1931) $\mu=100,000$, tensile strength (EN 12311-1) L/T of 400/300 N/50 mm and ultimate elongation (EN 12311-1) L/T of 40/40%.

SELFTENE BV BIADESIVO/V

Double-sided adhesive elastomeric polymer-bitumen vapour barrier membrane of 3 kg/m² (EN1849-1), reinforced with fibreglass mat, with water vapour permeability (EN 1931) $\mu=100,000$, tensile strength (EN 12311-1) L/T of 300/200 N/50 mm and ultimate elongation (EN 12311-1) L/T of 2/2%.

INNOVATIVE VAPOUR BARRIER MEMBRANES

WITH INCORPORATED HEAT ACTIVATED ADHESIVE FOR STICKING

NON HEAT-RESISTANT THERMAL INSULATION

TECTENE BV STRIP ALU POLYESTER

Elastoplastomeric polymer-bitumen vapour barrier membrane with incorporated adhesive for sticking insulating panels, made up of heat-adhesive strips distributed across 40% of the upper face of the sheet, 3 mm thick (EN1849-1) reinforced with aluminium foil coupled to a non-woven composite polyester fabric stabilised with fibreglass, with water vapour permeability (EN 1931) $\mu=1,500,000$, tensile strength (EN 12311-1) L/T of 250/120 N/50 mm and ultimate elongation (EN 12311-1) L/T of 15/20%.

TECTENE BV STRIP EP/V

Elastoplastomeric polymer-bitumen vapour barrier membrane with incorporated adhesive for sticking insulating panels, made up of heat-adhesive strips distributed across 40% of the upper face of the sheet, 3 mm thick (EN1849-1), reinforced with fibreglass mat, with water vapour permeability (EN 1931) $\mu=100,000$, tensile strength (EN 12311-1) L/T of 300/200 N/50 mm and ultimate elongation (EN 12311-1) L/T of 2/2%.

INNOVATIVE VAPOUR BARRIER MEMBRANES

WITH INCORPORATED HEAT ACTIVATED ADHESIVE FOR STICKING HEAT-RESISTANT THERMAL INSULATION

PROMINENT ALU POLYESTER

Elastoplastomeric polymer-bitumen vapour barrier membrane of 4 kg/m² (EN1849-1), with incorporated adhesive for sticking insulating panels, made up of heat-adhesive embossings, 5 mm thick, distributed across 40% of the upper face of the sheet, reinforced with aluminium foil coupled to a non-woven composite polyester fabric stabilised with fibreglass, with water vapour permeability (EN 1931) $\mu=1,500,000$, tensile strength (EN 12311-1) L/T of 250/120 N/50 mm and ultimate elongation (EN 12311-1) L/T of 15/20%.

PROMINENT POLYESTER

Elastoplastomeric polymer-bitumen vapour barrier membrane of 4 kg/m² (EN1849-1), with incorporated adhesive for sticking insulating panels, made up of heat-adhesive embossings, 5 mm thick, distributed across 40% of the upper face of the sheet, reinforced with non-woven composite polyester fabric stabilised with fibreglass, with water vapour permeability (EN 1931) $\mu=100,000$, tensile strength (EN 12311-1) L/T of 450/400 N/50 mm and ultimate elongation (EN 12311-1) L/T of 40/40%.

PROMINENT/V

Elastoplastomeric polymer-bitumen vapour barrier membrane of 4 kg/m² (EN1849-1), with incorporated adhesive for sticking insulating panels, made up of heat-adhesive embossings, 5 mm thick, distributed across 40% of the upper face of the sheet, reinforced with fibreglass mat, with water vapour permeability (EN 1931) $\mu=100,000$, tensile strength (EN 12311-1) L/T of 300/200 N/50 mm and ultimate elongation (EN 12311-1) L/T of 2/2%.

INNOVATIVE DRAINING VAPOUR BARRIERS

FOR THE DIFFUSION OF CONDENSATION AND CONNECTION TO THE SUPPORT WITH SEMI-ADHESION

DIFFUSER ALU POLYESTER

Elastoplastomeric polymer-bitumen vapour barrier membrane, of 4 kg/m² (EN1849-1), able to create a micro air space on the surface to which it is stuck for draining water vapour and connection in semi-adhesion with "bitumen nails" onto about 40% of the surface, obtained by torching the heat-adhesive embossings that protrude by about 3.5 mm from its lower face. The membrane reinforced with aluminium foil, coupled to a non-woven composite polyester fabric stabilised with fibreglass, has water vapour permeability (EN 1931) $\mu=1,500,000$, tensile strength (EN 12311-1) L/T of 250/120 N/50 mm and ultimate elongation (EN 12311-1) L/T of 15/20%.

THERMAL INSULATION

INSULATORS PRE-COUPLED WITH MEMBRANES

THERMOBASE PSE/120

Thermal insulation supplied in rolls with overlapping selvage such as THERMOBASE PSE/120 made up of insulating strips 5 cm wide and 100 cm long in sintered expanded polystyrene with a compression resistance of 10% (EN 826) ≥ 120 KPa [CS(10/120)] heat-bonded continuously to a polymer-bitumen membrane P4 110 cm wide to allow the elements to be overlapped longitudinally. The membrane is reinforced with non-woven composite polyester fabric stabilised with fibreglass and has a hot stability (EN 1110) of 120°C, flexibility (EN 1109) of -15°C, ultimate tensile strength (EN 12311-1) L/T of 600/400 N/5 cm and ultimate elongation (EN 12311-1) L/T of 40/40%.

THERMOBASE PSE/EX

Thermal insulation supplied in rolls with overlapping selvage such as THERMOBASE PSE/EX made up of insulating strips 5 cm wide and 100 cm long in extruded expanded polystyrene with a 10% compression resistance (EN 826) ≥ 200 KPa [CS(10/Y)200] heat-bonded continuously to a polymer-bitumen membrane P4 110 cm wide to allow the elements to be overlapped longitudinally. The membrane is reinforced with non-woven composite polyester fabric stabilised with fibreglass and has a hot stability (EN 1110) of 120°C, flexibility (EN 1109) of -15°C, ultimate tensile strength (EN 12311-1) L/T of 600/400 N/5 cm and ultimate elongation (EN 12311-1) L/T of 40/40%.

THERMOBASE PSE/PUR

Thermal insulation supplied in rolls with overlapping selvage such as THERMOBASE PUR made up of 5 cm wide and 100 cm long insulating strips of expanded polyurethane rolled continuously between two fibreglass mats or two bituminised foam boards which are continuously heat-bonded to a polymer-bitumen membrane P4 110 cm wide to allow the longitudinal overlap of the elements, with a 10% compression resistance (EN 826) ≥ 100 KPa [CS(10/Y)100]. The membrane is reinforced with non-woven composite polyester fabric stabilised with fibreglass and has a hot stability (EN 1110) of 120°C, flexibility (EN 1109) of -15°C, ultimate tensile strength (EN 12311-1) L/T of 600/400 N/5 cm and ultimate elongation (EN 12311-1) L/T of 40/40%.

WATERPROOF COVERING

VAPORDIFFUSER STRIP/V

Special elastoplastomeric polymer-distilled bitumen waterproofing membrane for application in semi-adhesion, dampness diffusion and laying surface shift distribution, with 40% of the lower face covered with heat-adhesive strips, with a mass per unit area of 2 kg/m² (EN1849-1), reinforced with fibreglass and featuring a tensile strength (EN 12311-1) L/T of 300/200 N/50 mm, ultimate elongation (EN 12311-1) L/T of 2/2% and cold flexibility (EN 1109) of -15°C.

PROTEADUO TRIARMATO

Multi-layer composite polymer-bitumen waterproofing membrane, 4 mm thick, such as PROTEADUO TRIARMATO, certified with the EuroAgrément I.T.C-CNR (formerly I.C.I.T.E.), made up of an upper layer in elastoplastomeric polymer bitumen with ring and ball softening point (EN 1427) of 150°C, a lower layer in elastomeric polymer bitumen with elastic recovery (NF XP 84-360) of 300% and a stabilised three-layer composite reinforcement with fibreglass between two spunbond polyester "non-woven fabrics", impregnated with elastomeric polymer bitumen. The membrane has a tensile strength (EN 12311-1) L/T of 750/650 N/50 mm, ultimate elongation (EN 12311-1) L/T of 50/50%, resistance to tearing (EN 12310-1) L/T of 250/250 N and cold flexibility (EN 1109) of -15°C for the upper layer and -25°C for the lower layer.

MINERAL PROTEADUO TRIARMATO

Multi-layer composite polymer-bitumen waterproofing membrane, covered with slate granules, 4 mm thick measured on the selvage, such as MINERAL PROTEADUO TRIARMATO, certified with the EuroAgrément I.T.C-CNR (formerly I.C.I.T.E.), made up of an upper layer in elastoplastomeric polymer bitumen with ring and ball softening point (EN 1427) of 150°C, a lower layer in elastomeric polymer bitumen with elastic recovery (NF XP 84-360) of 300% and a stabilised three-layer composite reinforcement with fibreglass between two spunbond non-woven polyester fabrics, impregnated with elastomeric polymer bitumen. The membrane has a tensile strength (EN 12311-1) L/T of 750/650 N/50 mm, ultimate elongation (EN 12311-1) L/T of 50/50%, resistance to tearing (EN 12310-1) L/T of 250/250 N and cold flexibility (EN 1109) of -15°C for the upper layer and -25°C for the lower layer.

HELASTA POLYESTER

Elastomeric polymer-bitumen waterproofing membrane, 4 mm thick, with a radial butadiene-styrene thermoplastic rubber base and distilled bitumen base, with ultimate elongation of 2000% and elastic recovery (NF-XP 84-360) of 300%, reinforced with spunbond polyester non-woven fabric, such as HELASTA POLYESTER 4, certified with the Agrément I.T.C-CNR (formerly I.C.I.T.E.). The membrane has a tensile strength (EN 12311-1) L/T of 900/700 N/50mm, ultimate elongation (EN 12311-1) L/T of 50/50%, resistance to tearing (EN 12310-1) L/T of 200/200 N, fatigue resistance (UEAtc) of over 1,000 cycles on new material and over 500 cycles on artificially aged material, cold flexibility (EN 1109) of -25°C and hot stability (EN 1110) of 100°C.

MINERAL HELASTA POLYESTER

Elastomeric polymer-bitumen waterproofing membrane, covered with slate granules, 4 mm thick measured on the selvage, with a radial butadiene-styrene thermoplastic rubber base and distilled bitumen base, with ultimate elongation of 2000% and elastic recovery (NF-XP 84-360) of 300%, reinforced with spunbond polyester non-woven fabric, such as MINERAL HELASTA POLYESTER 4, certified with the Agrément I.T.C-CNR (formerly I.C.I.T.E.). The membrane has a tensile strength (EN 12311-1) L/T of 900/700 N/50mm, ultimate elongation (EN 12311-1) L/T of 50/50%, resistance to tearing (EN 12310-1) L/T of 200/200 N, fatigue resistance (UEAtc) of over 1,000 cycles on new material and over 500 cycles on artificially aged material, cold flexibility (EN 1109) of -25°C and hot stability (EN 1110) of 100°C.

FLEXTER FLEX TESTUDO SPUNBOND POLYESTER

Elastoplastomeric polymer-bitumen waterproofing membrane, 4 mm thick, based on distilled bitumen, plastomers and elastomers, with composite reinforcement consisting of spunbond non-woven polyester fabric stabilised with fibreglass, FLEXTER FLEX TESTUDO SPUNBOND POLYESTER 4, certified with the Agrément I.T.C-CNR (formerly I.C.I.T.E.). The membrane has a tensile strength (EN 12311-1) L/T of 900/700 N/50 mm, ultimate elongation (EN 12311-1) L/T of 50/50%, resistance to tearing (EN 12310-1) L/T of 150/150 N, resistance to impact (EN 12691 - method A) of 1,250 mm, resistance to static load (EN 12730) of 20 kg, hot dimensional stability (EN1107-1), L/T of -0.3/0.3%, cold flexibility (EN1109) of -25°C and heat resistance (EN1110) of 140°C.

MINERAL FLEXTER FLEX TESTUDO SPUNBOND POLYESTER

Elastoplastomeric polymer-bitumen waterproofing membrane, self-protected with slate granules, 4 mm thick measured on the selvage, based on distilled bitumen, plastomers and elastomers, with composite reinforcement consisting of spunbond non-woven polyester fabric stabilised with fibreglass, MINERAL FLEXTER FLEX TESTUDO SPUNBOND POLYESTER 4 type, certified with the Agrément I.T.C-CNR (formerly I.C.I.T.E.). The membrane has a tensile strength (EN 12311-1) L/T of 900/700 N/50 mm, ultimate elongation (EN 12311-1) L/T of 50/50%, resistance to tearing (EN 12310-1) L/T of 150/150 N, hot dimensional stability (EN 1107-1), L/T of -0.3/0.3%, cold flexibility (EN 1109) of -25°C and heat resistance (EN 1110) of 140°C.

MINERAL REFLEX WHITE TREATMENT (to be added to the MINERAL membrane specifications)

To reduce energy consumption and limit "urban heat island" effects, the membrane will have a high solar reflectance of R = 45% combined with an extremely high thermal emissivity of E = 94%, so as to offer a Solar Reflectance Index SRI = 52 - 54%, achieved by means of MINERAL REFLEX WHITE special high saturation and luminosity white mineral self-protection.

HIGH REFLECTANCE AND HIGH EMISSIVITY PAINT

WHITE REFLEX

One-component white paint, based on polymers in an aqueous emulsion and special additives, flexible, resistant to atmospheric agents, with high solar reflectance and emissivity of infrared rays, able to increase the diffused light and the efficiency of the photovoltaic panels, to reduce the surface temperature of the waterproof covering during the daytime, promote the dissipation of the heat accumulated during the night and consequently produce consistent energy saving from air conditioning buildings. The paint has solar reflectance (ASTM C-1549) > 0.80, infrared emissivity (ASTM C-1471) > 0.85 and a Solar Reflectance Index SRI > 100%.



Technical specification

• TO USE OUR PRODUCTS CORRECTLY, CONSULT THE INDEX TECHNICAL SPECIFICATIONS • FOR FURTHER INFORMATION OR PARTICULAR USES, CONSULT OUR TECHNICAL OFFICE •

index
Construction Systems and Products

Internet: www.indexspa.it
For technical and commercial information: tecom@indexspa.it
Accounting department: index@indexspa.it
Export department: index.export@indexspa.it

Via G. Rossini, 22 - 37060 Castel D'Azzano (VR) - Italy - C.P.67 - Tel. (+39)045.8546201 - Fax (+39)045.518390



ing the numerous possible uses and the possible interference of conditions or elements beyond our control, we assume no responsibility regarding the results which are obtained. The purchasers, of their own accord and under their own responsibility, must establish the suitability of the product for the envisaged use.

The figures shown are average indicative figures relevant to current production and may be changed or updated by INDEX S.p.A. at any time without previous warning. The advice and technical information provided, is what results from our best knowledge regarding the properties and the use of the product. Consider