

NON-WALKABLE FLAT ROOF

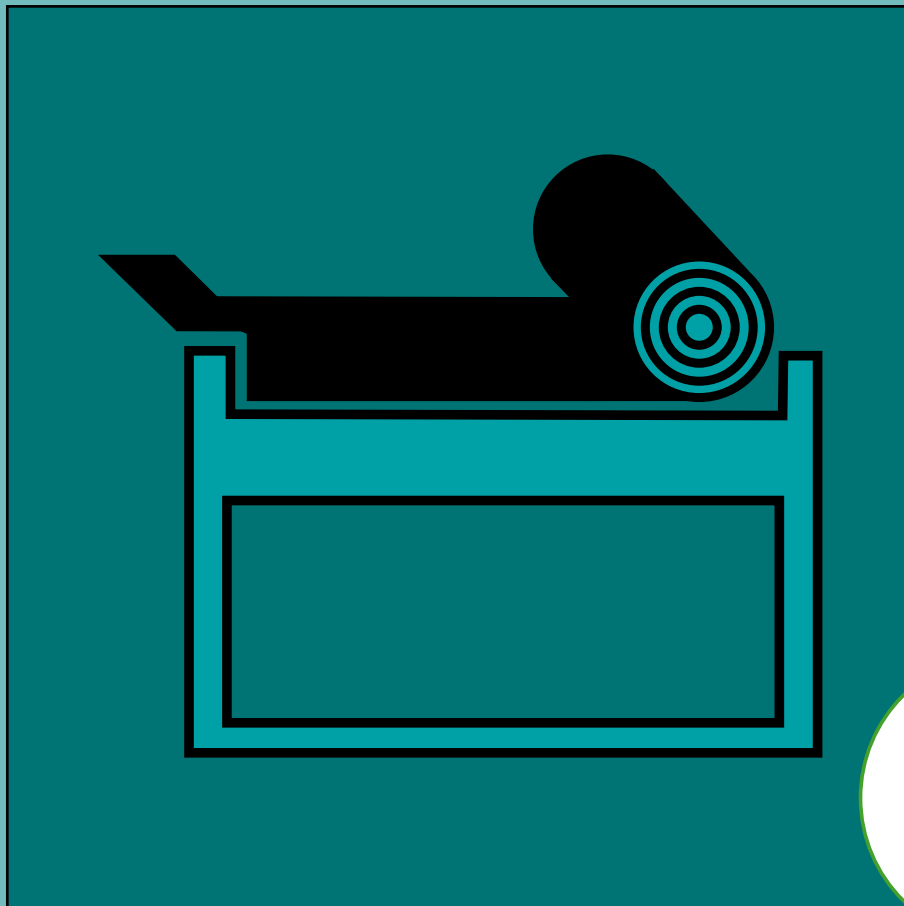

Waterproofing and thermal insulation of masonry roofs, pre-compressed pre-fabricated reinforced concrete roofs or roofs cast on site

In building, flat roofs mean an optimal use of space, freedom of expression and energy saving in the temperature control of the volumes below. The efficiency of the roof over time is guaranteed by correct design and implementation of its insulating layer and waterproof covering. The environmental issue of fulfilling the criteria of *sustainable building* must also be tackled from an overall standpoint.

A general view of sustainability implies design choices that do not only regard the energy containment of the building during its lifetime but also urban/landscape integration, the use of renewable sources of energy, the environmental impact of building products through the analysis of their life cycle LCA (Life Cycle Assessment), the impact of the building process, as well as a forecast of the environmental impact during the management and maintenance/repair stages, partial or total modification of the intended use for parts/all of the building, during its partial or total demolition and, at the end of its lifetime, recycling of the building materials.

INDEX S.p.A., the manufacturer of THERMOBASE thermal insulation and FLEXTER TESTUDO, HELASTA, PROTEADUO and MINERAL DESIGN waterproof sheets offers complete waterproofing and insulation systems for the building industry that can easily be adapted to different climatic conditions and the most varied types of roofs. The waterproof covering applied on thermal insulation and left visible as the top layer of the roof is subject to large changes in temperature, can easily be ripped by strong wind or perforated by strong hail and the ageing phenomena that tend to weaken it are accelerated by the presence of the insulation. Thermal insulation that is sensitive to heat and humidity is subject to reductions in thickness or deformations and can also be unrolled or broken down by the action of the wind. The waterproof systems FLEXTER TESTUDO, HELASTA, PROTEADUO and MINERAL DESIGN consist of flexible membranes at low temperatures, which are resistant to thermal ageing and to U.V. rays. The thermal insulation THERMOBASE is resistant to heat, compact and is not subject to reductions in thickness or deformations. It is no longer necessary to put down a layer of gravel on roofs as the FLEXTER TESTUDO, HELASTA, PROTEADUO and MINERAL DESIGN sheets stuck onto THERMOBASE are not ripped by the wind and are resistant to ageing. The waterproof system is subject to mechanical strain generated by the movements of the surface on which it is resting. It must be resistant to cracks due to the shrinkage of the concrete and the alternating of the opening and closing cycles of the joints between the pre-fabricated tiles or insulating panels below. The waterproof systems FLEXTER TESTUDO, HELASTA, PROTEADUO and MINERAL DESIGN are made up of membranes with high mechanical resistance and excellent elasticity. They are resistant to fatigue, shear strain and tearing. The THERMOBASE insulation, which is stable and non-deformable, is an ideal laying surface for waterproof membranes. With the arrival of the innovative vapour barrier membranes SELTENE BIADESIVO, TECTENE BV STRIP and PROMINENT, the fruit of Index's research, which allow the layer of thermal insulation to be stuck without molten oxidised bitumen being spread onto it, the site is safer and the environmental pollution of the laying operations is reduced.

Not very commonly used in the past, flat roofs have developed over recent years with the arrival of concrete and the new architectural trends developed by Rationalism in the early 20th century, whose best known exponent was Le Corbusier.

ENERGY SAVING IN BUILDINGS

The building envelope encloses the living environment in which comfortable climatic and environmental conditions are to be maintained and therefore more stable than the external environment, which is marked by high variability. In order to obtain this, energy obtained from fossil fuels is consumed and the environment is polluted through the emission of harmful substances and carbon dioxide, leading to the greenhouse effect and heating up the planet. Therefore, the building industry, like other human and industrial activities, is involved in the reduction of energy consumption, an objective that governments all over the world are imposing through laws, technical regulations and incentives.

Terraces, which constitute the horizontal partition of the building's envelope, are also involved in the problem of energy saving.

Energy consumption in existing buildings is the first problem to be considered because it is ongoing, even if, as can be seen below, it is not the only one considered in the design principles of bio-architecture.

Although it has a warmer climate, due to the poor insulation in Italy the total energy requirement of buildings, mainly for heat energy, is 300 kWh/m²/year, whereas in countries with better insulation, such as Sweden it is 60 kWh/m²/year and in Germany 200 kWh/m²/year. In Italy there are peaks of 500 kWh/m²/year.

The legislative provisions for energy saving are concerned with reducing heat dispersion in buildings through issuing maximum thermal transmittance limits of the building envelope according to the climatic area in which they are located; this is fulfilled by increasing thermal insulation.

NON-WALKABLE FLAT ROOFS AND BIO-ARCHITECTURE

Naturally, respecting the thermal transmittance limits during the design and building stages makes no sense if the design solution does not last over time, and the durability of the insulation does not only depend on the quality of the insulating material.

Therefore, as well as energy containment, the design principles of bio-architecture also consider urban/landscape integration, the use of renewable sources of energy, the environmental impact of building products through the analysis of their life cycle LCA (Life Cycle Assessment), the impact of the building process, as well as a forecast of the environmental impact during the management and maintenance/repair stages, partial or total modification of the intended use for parts/all of the building, during its partial or total demolition and, at the end of its lifetime, recycling of the building materials.

One of the main requirements for *sustainable building* is the durability of the technical solutions provided by the design and their restoration without demolition, which both lead to a lower consumption of resources and less waste, therefore INDEX has not stopped at just producing high performance insulating materials but, in order to maintain the thermal insulation performance over time, it has produced specific technical publications suggesting the best protection systems that are safe and easy to maintain, repair and restore.

The polymer-bitumen membranes are easy and cheap to repair by sticking a piece of membrane onto the damaged part and, unlike other types of materials, also onto old coverings without any specific treatments.

This detail and exclusive characteristic is also used to extend the durability of the waterproof covering.

INTEGRAL OVERLAPPING AND TYPICAL LIFETIME

This describes the property of a certain type of sheets/waterproof coverings to be covered with a new layer of the same type, which becomes an integral part in synergy with the existing system.

- Polymer-bitumen membranes, unlike other materials, can be bonded to each other and the heat bonding of a new layer onto an old covering allows recovery without demolition and therefore without producing waste
- The repair obtained with the new layer reinforces the existing one and determines the formation of a new and better performing multi-layer arrangement
- The repair obtained with the new layer extends the lifetime of the existing covering

The DVT (typical lifetime established by the CSFE, French Waterproofing Trade Association and the international BWA Bitumen Waterproofing Association) conventionally summarises the total lifetime of every type of layered arrangement with a reparable covering by overlapping without demolition, which can last up to 90 years in some cases!

FLAT ROOFS AND HEAT ISLANDS

Another important problem in which roof terraces are involved is the reduction of the effects of "heat islands".

The EPA (Environmental Protection Agency), the US agency for the protection of the environment, launched a campaign for the reduction of the "Heat Island Effect" a long time ago. This refers to the phenomenon of raised temperatures in urban areas compared to the temperature of rural areas, which can cause serious consequences in summer time. These are real "Heat Islands" that tower over the cities, where the temperature difference can range from 1 to 6°C.

In summer a dangerous peak of electrical absorption occurs due to air conditioning, hence the risk of blackouts, along with an increase in pollution levels, diseases and deaths.

PHENOMENON OF URBAN HEAT ISLANDS

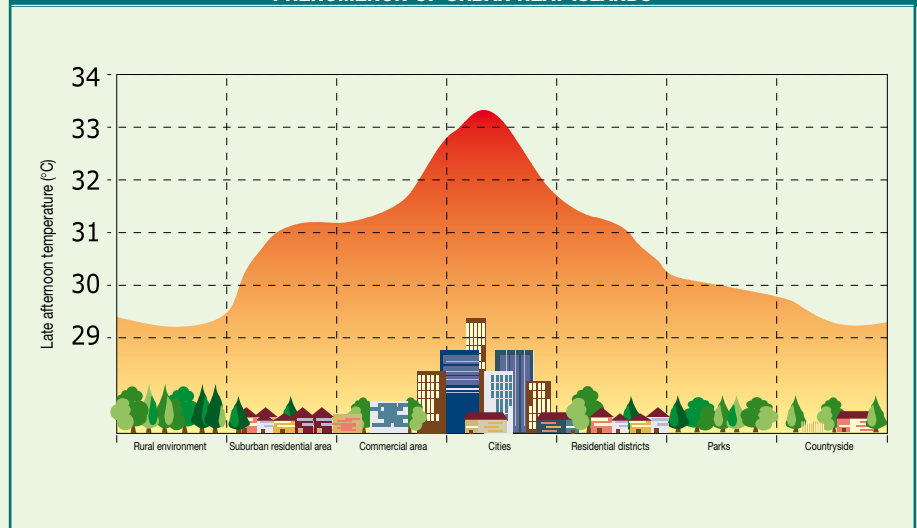

The strategies identified by the EPA to reduce urban overheating are:

- Increasing green areas, including roofs (Green Roofs)
- **Cooling the roofs of buildings with reflecting paints or membranes (Cool Roofs)**
- Cooling urban paving, including terraces (Cool Pavements)

Hence the importance of the reflecting capacity of solar radiation along with the infrared emissivity of the roof that are expressed together by the SRI (Solar Reflectance Index) which must be high and in general refers to light colours.

Levels of temperature reached by the waterproof covering with different surface finishes exposed in the same conditions to summer solar radiation	
Surface finish	Max Temp.
Black bituminous membrane	78°C
Grey slate membrane	74°C
White slate membrane	70°C
Painted aluminium membrane	67°C
MINERAL REFLEX WHITE membrane	65°C
Self-protected membrane with copper foil	60°C
Self-protected membrane with aluminium foil	55°C
Membrane with WHITE REFLEX paint	42°C

The increase in the reflectance and emissivity provided by the WHITE REFLEX paint applied to the waterproof covering		
Surface	Reflection	Emissivity
Black bituminous membrane	<10% (<0,1)	>80% (>0,8)
Painted aluminium membrane	40±45% (0,40±0,45)	<60% (<0,6)
MINERAL REFLEX WHITE membrane	45% (0,45)	<94% (<0,94)
Membrane with WHITE REFLEX paint	>80% (>0,80)	>90% (>0,90)

The covering painted with WHITE REFLEX in compliance with the requirements of the Green Building Council responds to the LEED-SS Credit 7.2-Heat Island Effect: Roof, 1 Point for Options 1 and 3 for flat roofs		
SRI (Solar Reflectance Index)	LEED Standard	SRI≥78
	Membrane with WHITE REFLEX paint	SRI≥100
The covering painted with WHITE REFLEX in compliance with the requirements of the Green Building Council responds to the LEED-SS Credit 7.1 and 7.2- Copertura parcheggi and Heat Island Effect for flat roofs		
SRI (Solar Reflectance Index)	LEED Standard	SRI≥29
	Self-protected membrane MINERAL REFLEX WHITE	SRI>52±54%

GBC ITALIA (Green Building Council) AND LEED CERTIFICATION



GBC Italia, which INDEX belongs to, has the task of using the common guidelines to everyone in the **LEED** international community to develop the characteristics of the **LEED** Italia system, which must

take into consideration the specific climatic, building and legislative conditions in Italy.

The **LEED** standards are parameters for sustainable building developed in the USA and applied in 40 countries throughout the world. They indicate the requirements for eco-compatible buildings, able to “work” sustainably and self-sufficiently energy-wise. It is essentially a rating system for the development of “green” buildings.

LEED is a certification, which may be obtained on a voluntary basis, where the actual designer deals with collecting the data for the assessment. The system is based on the award of credits for each of the requirements that characterise the sustainability of the building.

The certification level obtained comes from the sum of the credits.

The assessment criteria used by **LEED** (2009 version) are grouped into six categories (+1 only valid in the USA), which envisage one or more compulsory prerequisites and a number of environmental performances that attribute the building’s final score:

- Sustainable sites (1 prerequisite, 26 points)
- Efficient water consumption (1 prerequisite, 10 points)
- Energy and atmosphere (3 prerequisites, 35 points)
- Materials and resources (1 prerequisite, 14 points)
- Indoor environmental quality (2 prerequisites, 15 points)
- Innovation and design process (6 points)
- Regional priority (4 points) only applicable in the USA

There are 4 rating levels:

- Certified: between 40 and 49 points
- Silver: between 50 and 59 points
- Gold: between 60 and 79 points
- Platinum: more than 80 points

The following point in the **LEED** regulations includes the solar reflectance index:

• **SS Credit 7.1: Heat island effect: Non roof Option 2 - Place a minimum of 70% of parking spaces under cover (defined as under ground, under deck, under roof or under a building). Any roof used to shade or cover parking, if it is not made of support structures covered in vegetation, must have an SRI of at least 29.**

INDEX MINERAL REFLEX WHITE membranes and membranes painted with INDECOLOR COOL REFLEX have a Solar Index Reflectance SRI ≥ 29 which allow point SS-7.1 to be fulfilled.

• **SS Credit 7.2: Heat island effect: Roof Option 1 - Use roofing materials with a Solar Reflectance Index (SRI) equal to or greater than the values indicated in the table below for a minimum of 75% of the roof surface.**

Roof type	Slope	SRI
Low sloped roof	≤2:12(9,5°-16,7%)	78
High sloped roof	>2:12(9,5°-16,7%)	29

Option 3 - Install high albedo and vegetated roof surfaces that, in combination, meet the following criteria: (Area roof meeting minimum SRI/0.75) + (Area of vegetated roof/0.5) ≥ Total roof area

INDEX MINERAL REFLEX WHITE membranes and membranes painted with INDECOLOR COOL REFLEX have a Solar Index Reflectance SRI ≥ 29

Membranes painted with WHITE REFLEX have a Solar Index Reflectance SRI ≥ 78

• **EA Credit 2: On-site Renewable Energy** Increase in the efficiency of photovoltaic solar panels installed on the roof.

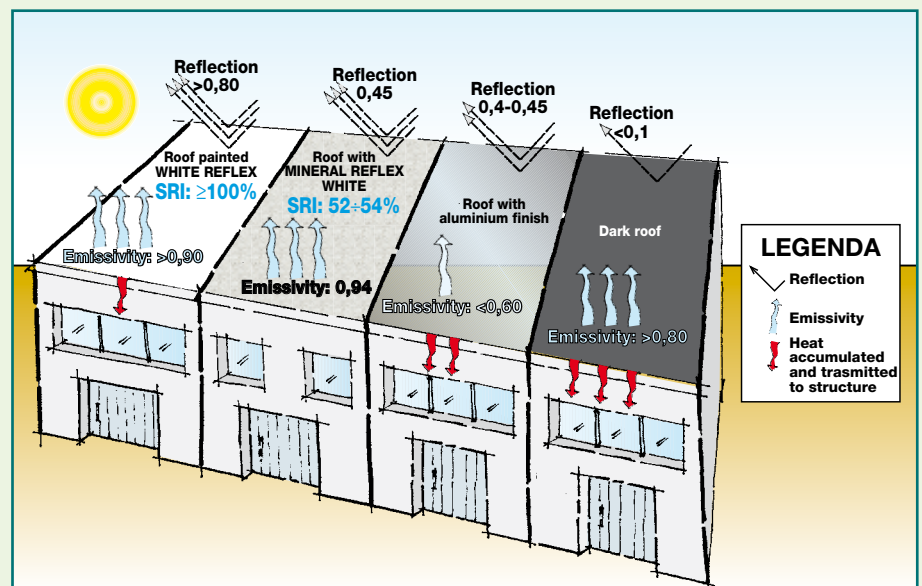

The use of a light coloured surface finish on the visible waterproof covering (for example: a MINERAL membrane self-protected with white slate) which reflects more than a black membrane, is a precaution that fulfils the requirements of *sustainable building* because, lowering the surface temperature of the waterproofing exposed to the sunlight, extends its lifetime and reduces energy consumption from air conditioning the rooms below in the summer.

The reinforcement of the reflecting capacity of the sun's rays as well as the increase in infrared emissivity of the covering, which can be obtained by painting the finish slate membrane using WHITE REFLEX paint, contributes to the reduction of the urban heat island phenomenon in compliance with the Green Building Council *LEED* standards, as well as increasing the extent of the benefits already mentioned.

The following tables indicate the benefits brought about by the WHITE REFLEX paint.

STRATIFIED ELEMENTS

1. Support
2. Primer
3. Vapour barrier
4. Thermal insulation
5. Waterproofing membrane
- 6a. Highly reflective WHITE REFLEX paint
- 6b. Self-protected waterproofing membrane MINERAL REFLEX WHITE

"COOL ROOF"

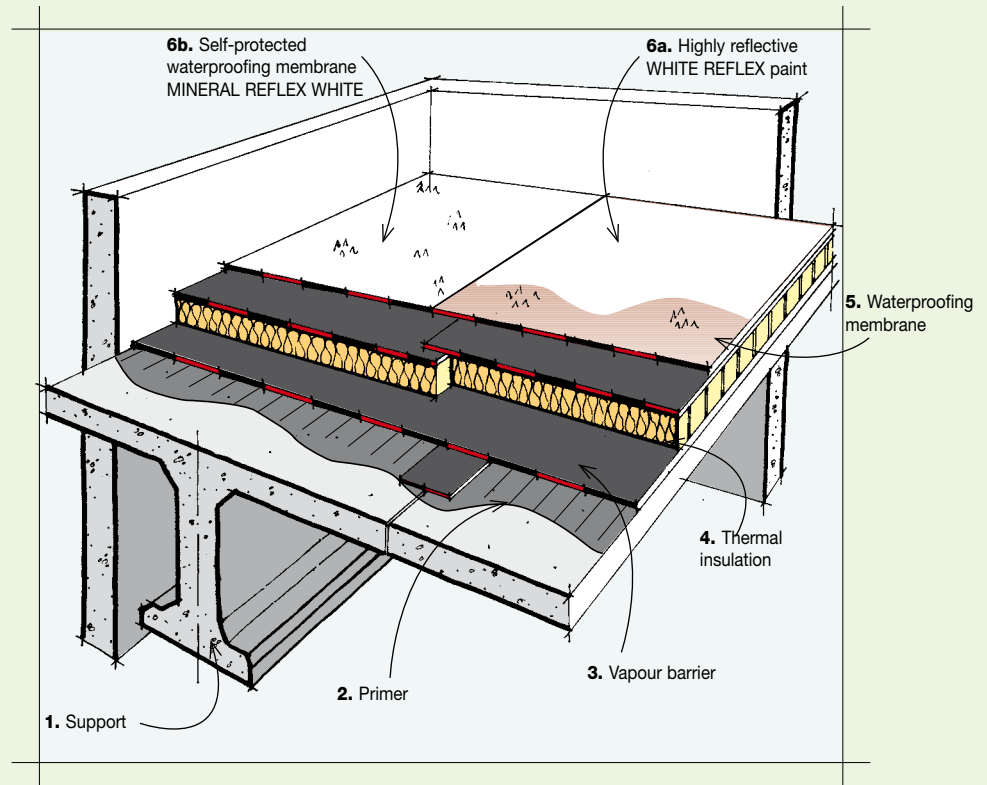

FLAT ROOFS AND RENEWABLE ENERGY

The trend of architecture for sustainable building is not limited to the design of a "conservative" envelope from an energy point of view, but current design research intends to make the building envelope perform an "active" energy role.

Flat roofs allow substantial freedom in the orientation of the installations for solar collection both for solar heating and photovoltaic solar power.

The WHITE REFLEX paint, with a double effect, also provides a significant increase in the energy performance of the photovoltaic solar panels to be installed on the flat roof, both because it reduces the temperature of the covering and therefore increases the performance of the panels which are more efficient if they work at a lower heat regime, and because it increases the diffused and reflected light which is added to that collected by direct radiation. This second effect is more marked in systems that use latest generation panels with cylindrical pipes in CIGS (copper, indium, gallium, (di)selenide) film,

which do not require fixing elements that cross the covering or heavy ballasts and which are sensitive to the light diffused and reflected by the waterproof covering also on the lower face.

DESIGN CERTIFICATION

In Italy the legislation in force for the certification of the environmental quality of a construction is fragmentary and mainly refers to energy consumption, hence there is a lack of tools for a holistic evaluation of the building's environmental impact.

LEED (Leadership in Energy and Environmental Design) certification, which was devised in the USA, has now become widespread all over the world. It is promoted in Italy by the GBC, whose main aim is to encourage sustainable building on the Italian market through the *LEED* system, developed over more than 10 years' experience by USGBC. In this sense GBC Italia is aiming to make use of the result of the work carried out by USGBC in the USA and adapt the various aspects tackled by it to the Italian situation.



WATERPROOFING AND THERMAL INSULATION NON-WALKABLE FLAT ROOF

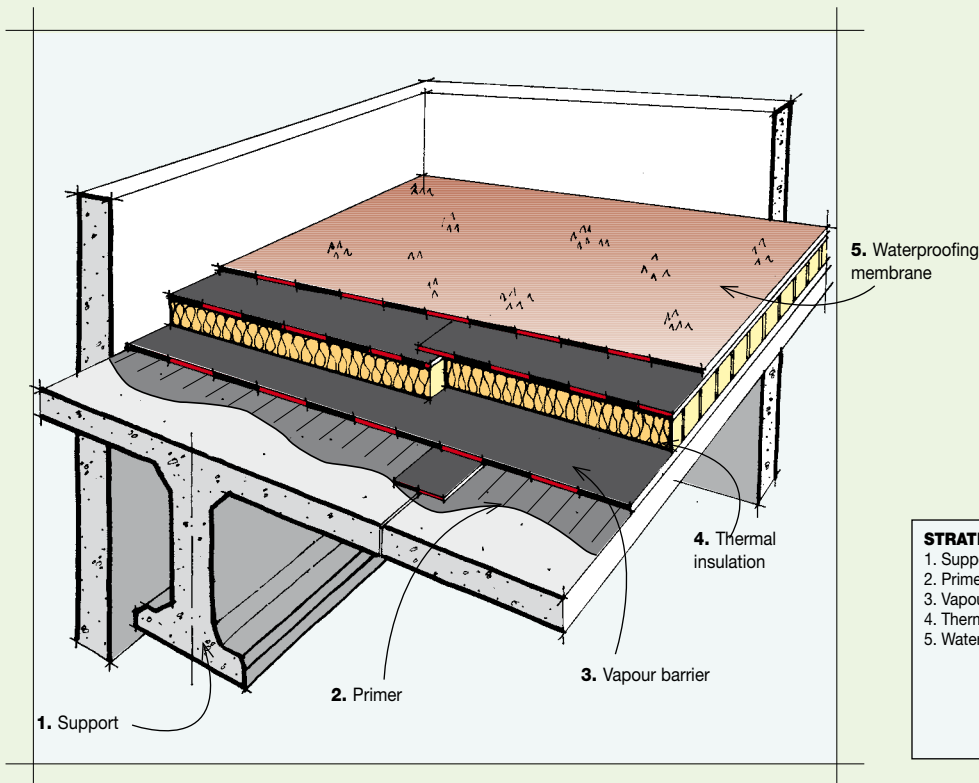

STRATIFIED ELEMENTS	
1.	Support
2.	Primer
3.	Vapour barrier
4.	Thermal insulation
5.	Waterproofing membrane

PRIMER

The primer penetrates into the pores of concrete surfaces, stops dust and has the job of promoting adhesion on the surfaces to which the membranes must be stuck. INDEVER is a traditional solvent-based bituminous primer; the ECOVER water-based primer is more innovative and has

reduced environmental impact. The whole surface to be covered and the vertical parts onto which the waterproof layer must be stuck, are painted with a coat of about 300 g/m² INDEVER adhesion bituminous primer, a solution based on oxidised bitumen, additives and solvents, with solid content

(UNI EN ISO 3251) of 40% and viscosity (UNI EN ISO 2431) of 12-17 s, or ECOVER, with a water-based bituminous emulsion and solid content (UNI EN ISO 3251) of 37% using 250-400 g/m².

VAPOUR BARRIER

The water vapour, which during the winter season migrates towards the outside of the heated building, meets with the opposition of the waterproof layer under which it could condense and therefore dampen the adjacent thermal insulation. Wet thermal insulation does not insulate any longer and can be deformed, hence damaging all the stratified elements. Therefore, it is necessary to stop the vapour before it reaches the thermal insulation in a sufficiently warm point of the stratified elements to make the amount of condensation that could form negligible. The layer that protects the insulation from the vapour is called the "vapour barrier". For a roof with a covering exposed to the external environment without ballast, the connection of the vapour barrier to the concrete support is of particular importance. To oppose the force of the wind and to guarantee the dimensional stability of the stratified elements subject to heat variations, except for in special cases, the connection must be made with total adhesion. To prevent the formation of bubbles on the vapour barrier generated by concrete supports that are still damp, it is appropriate for the vapour barrier + insulation + 1 layer of the covering all to be laid at the same time.

	Traditional	Innovative cold-bonded double-sided adhesive (with cold bonding of the insulation incorporated)	Innovative heat-bonded (with heat bonding of the insulation incorporated)
Vapour barrier on roofs of rooms with low humidity (relative humidity <80% at 20°C)	case A DEFEND - 3 mm heat-bonded adhesive under stuck insulation (1)	case C SELTENE BV BIADESIVO POL. SELTENE BV BIADESIVO/V cold-bonded adhesive under stuck insulation (*) (2)	case E TECTENE BV STRIP/V PROMINENT/V heat-bonded adhesive under stuck insulation (3)
Vapour barrier on roofs of rooms with high humidity (relative humidity ≥80% at 20°C)	case B DEFEND ALU POL. - 3 mm heat-bonded adhesive under stuck insulation (1)	case D SELTENE BV BIADESIVO ALU POLYESTER cold-bonded adhesive under stuck insulation (*) (2)	case F TECTENE BV STRIP ALU POL. PROMINENT ALU POL. heat-bonded adhesive under stuck insulation (3)
Special case of draining vapour barrier on roofs of rooms with very high humidity			case G DIFFUSER ALU POL. heat-bonded semi-adhesive + "case A" or "case E"

(*) System to be used for surface areas of ≤500 m²
 (1) Insulation stuck with molten oxidised bitumen
 (2) Insulation cold-bonded onto the upper self-adhesive face of the vapour barrier
 (3) Insulation stuck by heat bonding of the strips or the heat-adhesive embossings on the upper face of the vapour barrier
A; B. On DEFEND and DEFEND ALU POLYESTER heat-resistant insulating panels and THERMOBASE PUR and THERMOBASE FR are chosen.
C; D. On SELTENE BV BIADESIVO polystyrene or polyurethane panels can be stuck, and THERMOBASE PSE, THERMOBASE PSE/EX and THERMOBASE PUR
E; F. Heat bonding on PROMINENT is reserved for heat-resistant thermal insulation and THERMOBASE PUR whereas on TECTENE BV STRIP polystyrene and polyurethane panels can be stuck, and THERMOBASE PSE, THERMOBASE PSE/EX and THERMOBASE PUR using suitably trained labour.

THERMAL INSULATION

This is required for containing energy consumption and limiting any dilations of the load-bearing structure; it also prevents internal condensation of water vapour on cold walls. Either fibrous or cellular, the most common insulators are: glass or rock mineral fibre panels, polyurethane and expanded polystyrene panels, perlite agglomerates and cellulose fibres, cellular glass, cork, etc.

INDEX S.p.A. produces the THERMOBASE insulation in rolls, made up of strips of insulating material already stuck onto a polymer-bitumen membrane, a product that meets the specifications of *sustainable building* as the membrane/insulation coupling in the factory reduces the laying operations on the roof and the consequent emission of fumes, smells and noise into the environment.

For terraces, the types envisaged in the event of using THERMOBASE are:

- THERMOBASE PUR/35-P4
- THERMOBASE PSE/120-P4
- THERMOBASE PSE/EX-P4
- THERMOBASE FR/100-P4

Except for in the system known as an “inverted roof”, the insulation is always protected by the waterproof covering. The insulating materials are produced in different types, densities and dimensions, according to their destination. It is important to choose materials of the type expressly declared by the manufacturer as being suitable for roof insulation and to be

stuck and coated with polymer-bitumen membranes and bituminous materials in general. Cellular insulating materials are preferable because, in the event of leaks in the waterproof layer, they absorb less water.

Heat-resistant insulating panels (perlite, expanded polyurethane, cork, mineral wools), such as THERMOBASE PUR and THERMOBASE FR/100 can be stuck with molten oxidised bitumen.

For safer laying, reducing the risk of burns and the emission of fumes and smells, the expanded polyurethane panels and THERMOBASE PUR can also be heat-bonded onto the PROMINENT and TECTENE BV STRIP EP membranes and can be heat-bonded directly to the waterproof covering suggested below. Expanded polystyrene insulating panels can be heat-bonded onto TECTENE BV STRIP EP or cold-bonded onto SELFTENE BV BIADESIVO and then before laying the waterproof layer they must be protected with the self-heat-adhesive membrane in the AUTOTENE BASE series, which is stuck alone onto the polystyrene panel using the heat transmitted from the heat bonding of the waterproof layer above; alternatively rolls of insulation pre-coupled to a membrane of the THERMOBASE PSE/120 or THERMOBASE PSE/EX type can be used.

The thickness of the insulation must be sufficiently high to prevent the dew point dropping

below the vapour barrier and must comply with legislation in force on energy containment in buildings.

THERMOBASE PSE/120-P4							
Thickness	30	40	50	60	70	80	90
Thermal resistance R(m ² K/W)	0,837	1,114	1,377	1,650	1,929	2,203	2,352

THERMOBASE PSE/EX-P4					
Thickness	30	40	50	60	80
Thermal resistance R(m ² K/W)	0,921	1,224	1,482	1,776	2,234

THERMOBASE PUR/35-P4				
Thickness	30	40	50	60
Thermal resistance R(m ² K/W)	0,964	1,283	1,588	1,902

THERMOBASE FR/100-P4			
Thickness	40	50	60
Thermal resistance R(m ² K/W)	0,80	1,05	1,25

WATERPROOF COVERING

This is the continuous layer that prevents the passage of water through the roof, protects and keeps the thermal insulation dry, conserving energy containment over time, for which it was designed.

A roof with a visible covering is the most common and widespread solution for industrial and commercial buildings and is often very large, therefore the economic factor pushes for leaving out the use of heavy protection (gravel or flat roof) which also affects the costs of the load-bearing structure and maintenance and repair costs.

The visible covering is under more strain as it is exposed to the elements therefore it is important to choose long-lasting membranes.

The membranes suggested in this publication are:

- PROTEADUO TRIARMATO 4mm, multi-layer composite membrane;
- HELASTA POLYESTER 4mm, elastomeric membrane;
- FLEXTER TESTUDO SPUNBOND POLYESTER 4mm, elastoplastomeric membrane.

The membranes are all covered by the Agrément ITC-CNR (former ICITE) which certifies their durability and relative constant periodic inspections.

It must be considered that the waterproof covering is a continuous element that almost always covers discontinuous element; therefore the mechanical resistance and elasticity of the covering also play an important role as a good grip must be guaranteed on concrete laying surfaces where there may be cracks or where the joining lines of prefabricated concrete panels or insulating panels undergo opening and closing cycles generated by temperature dif-

ferences and can cause fatigue of the covering above causing the waterproofing to crack.

The waterproof covering must have high mechanical resistance and elasticity and a sufficient resistance to impact and static load to resist against the strains to which it is subjected. The high fatigue resistance of the materials - which is also high at low temperatures in the case of the elastomeric and composite membranes - allows the choice of the connection of the covering to the laying surface in total adhesion. The completely stuck covering is more stable and more resistant to impact and static load, wind and hail stones and in the event of accidental tearing, not much water passes through.

A visible covering is exposed to hail stones whereas a covering underneath a heavy protection (gravel or flat roof) is clearly resistant to hail stones, such as in the “inverted roof” system. However, to increase the resistance of exposed coverings it is best:

- to use elastomeric membranes (HELASTA, PROTEADUO TRIARMATO) reinforced with non-woven polyester fabric laid in a double layer
- to use membranes with a slated finish as the top layer (MINERAL HELASTA, MINERAL PROTEADUO TRIARMATO).

The recommended connection to the laying surface for the visible covering is in total adhesion which, as well as the benefits already stated, fights the phenomenon of reptation which can occur in colder climates on exposed coverings without heavy protection.

Temperature variations produce a continuous alternation of contractions and relaxations of the waterproof covering leading to a progres-

sive centralisation of the covering, which drags the layers connected to it towards the geometric centre of the roof causing folds and detachments from the corners and edges and from all parts that stick out from the covering (chimneys, skylights, etc.) to which it is connected. Hence the importance of total adhesion between all the layers and the vapour barrier to the concrete support as well as care in performing the detailed operations on the fixed points of the roof (external walls, drains, chimneys, skylights, etc.)

Only in the case of “inverted roofs” and for visible coverings laid directly onto concrete supports is it recommended to use semi-adhesion, as an alternative to total adhesion, that is to prevent the formation of bubbles on the covering due to humidity trapped in damp supports transformed into vapour when they are exposed to the sun; however, in these cases the problem of reptation is almost non-existent or notably reduced.

The membranes recommended are all certified with the Agrément ITC-CNR (former ICITE) and, in compliance with relative EC marking, they can only be laid in a single layer 4 mm thick, however, with the view of increased safety and in relation to the fact that repair work in the event of a fault on the covering is increasingly expensive, it has become common practice to lay a double layer.

Laying a single layer is only permitted in the event of laying on a non-insulated concrete support with the application of the vapour diffusion layer VAPORDIFFUSER/V which guarantees strong adhesion onto about 40% of the surface and in the case of an inverted roof, where a single layer is normally laid as the pro-

(See following)

(See previous)

tected covering lives at a constant temperature and is under less strain but for which it is still possible to use a double layer.

The systems recommended in this publication are as follows:

• **Single layer on non-insulated concrete support**

- VAPORDIFFUSER/V + MINERAL PROTEADUO TRIARMATO 4 mm
- VAPORDIFFUSER/V + MINERAL HELASTA POLYESTER 4 mm
- VAPORDIFFUSER/V + MINERAL FLEXTER TESTUDO SPUNBOND POLYESTER 4 mm o in alternativa MINERAL REFLEX WHITE FLEXTER TESTUDO SPUNBOND POLYESTER 4 mm
- VAPORDIFFUSER/V + MINERAL DESIGN TRIARMATO

• **Single layer on inverted roof under extruded polystyrene weighed down with gravel**

- PROTEADUO TRIARMATO 4mm
- HELASTA POLYESTER 4mm
- FLEXTER TESTUDO SPUNBOND POLYESTER 4 mm

• **Double layer with visible covering on heat-resistant thermal insulation**

- HELASTA POLYESTER 4 mm + MINERAL

- PROTEADUO TRIARMATO 4 mm
- HELASTA POLYESTER 4 mm + MINERAL HELASTA POLYESTER 4 mm
- FLEXTER TESTUDO SPUNBOND POLYESTER 4 mm + MINERAL FLEXTER TESTUDO SPUNBOND POLYESTER 4 mm o in alternativa MINERAL REFLEX WHITE FLEXTER TESTUDO SPUNBOND POLYESTER 4 mm
- FLEXTER TESTUDO SPUNBOND POLYESTER 4 mm + MINERAL DESIGN TRIARMATO

• **Double layer with visible covering on non-heat-resistant thermal insulation**

- AUTOTENE BASE EP POLYESTER + MINERAL PROTEADUO TRIARMATO 4 mm
- AUTOTENE BASE EP POLYESTER + MINERAL HELASTA POLYESTER 4 mm
- AUTOTENE BASE EP POLYESTER + MINERAL FLEXTER TESTUDO SPUNBOND POLYESTER 4 mm o in alternativa MINERAL REFLEX WHITE FLEXTER TESTUDO SPUNBOND POLYESTER 4 mm
- AUTOTENE BASE EP POLYESTER + MINERAL DESIGN TRIARMATO

• **When laying membranes on the thermal insulation THERMOBASE, using a double layer is automatic**

- THERMOBASE + MINERAL PROTEADUO TRIARMATO 4 mm
- THERMOBASE + MINERAL HELASTA POLYESTER 4 mm
- THERMOBASE + MINERAL FLEXTER TESTUDO SPUNBOND POLYESTER 4 mm o in alternativa MINERAL REFLEX WHITE FLEXTER TESTUDO SPUNBOND POLYESTER 4 mm
- THERMOBASE + MINERAL DESIGN TRIARMATO

The use of membranes and durable systems certified with an Agrément such as those suggested in this document meets the specifications of *sustainable building* as the primary requirement of the durability of the system is fulfilled, hence delaying the repair and/or demolition work timescales implies a lower consumption of raw materials, less energy consumption, less waste production and lower emissions of pollutants and greenhouse gases over time.

LIGHT PROTECTION (self-protection with slate, painting)

Energy saving, the reduction of heat islands and synergic integration with photovoltaic solar panels with WHITE REFLEX paint

The reinforcement of the reflecting capacity of the sun's rays as well as the increase in infrared emissivity of the covering, which can be obtained by painting the finish slate membrane using WHITE REFLEX paint, contributes to the reduction of the "urban heat island" phenomenon in compliance with the Green Building Council LEED standards, as well as increasing the extent of the benefits already mentioned.

The reduction in temperature and the diffused light increase the efficiency of photovoltaic panels.

The performance of the panels does indeed decrease by approximately 5% for every 0.5 °C deviation from the temperature of 25°C (temperature at which best rated panel performance is obtained).

The WHITE REFLEX paint, through a double effect, provides a significant increase in the energy performance of the photovoltaic solar panels to be installed on the flat roof, both because it reduces the temperature of the covering and consequently increases the performance of the panels which are more efficient if they work at a lower heat regime and because it increases the diffused and reflected light which is added to that collected by direct radiation.

The durability of the paint plays an important role in this case, therefore painting onto the slated surface of the waterproof covering is recommended onto which excellent adhesion is obtained.

Preparing the surfaces

The surfaces must have a sufficient slope to allow regular draining of stormwater; WHITE REFLEX is not suitable on flat surfaces with prolonged water stagnation.

The surfaces must be clean, dry and free from impurities or old paint.

Application

Dilute with water (10-20%) and apply the first coat. The second coat is applied after at least 6 hours, when the surface is completely dry, with a maximum dilution of 10%.

We strongly recommend applying two coats, crossing them over if possible. The product can be applied with a paintbrush, roller, large brush or it can be sprayed on.

The consumption depends on the nature and porosity of the support; on slated membranes the consumption is 350-450 g/m² per coat.

The energy saving and reduction in heat islands due to the self-protected membrane with special high saturation and luminosity white slate MINERAL REFLEX WHITE

MINERAL REFLEX WHITE FLEXTER TESTUDO is intended to be left on view and the special white mineral finish of the compact and adherent upper face has a high capacity to reflect the solar rays which, along with the high infrared emissivity, in the summer season on the roofs to which it is applied, allows less heat to be absorbed during the daytime and to dispose of the heat absorbed during the night more quickly, hence obtaining energy saving on the air conditioning system of the rooms below.

The high reflectance of the membrane lowers the temperature of the waterproof covering and consequently provides a benefit for the rooms below the roof, as well as the covering itself being exposed to a lower thermal regime, which increases its lifetime.

The temperature reduction of the covering along with the high reflectance (albedo) increases the performance of the photovoltaic solar panels to be installed on the roof, both because at low temperatures they perform better and because increasing the luminosity around them increases the performance of the panel during the evening.

MINERAL REFLEX WHITE FLEXTER TESTUDO contributes to the reduction of overheating in cities due to Urban Heat Islands.

The membrane's reflectance properties are certified by the EELab (Energy Efficiency Laboratory of the Department of Mechanical and Civil Engineering at the University of Modena and Reggio Emilia).

The special Mineral Reflex White self-protection is applied onto two membranes, both certified with Agrément:

- MINERAL REFLEX WHITE FLEXTER TESTUDO SPUNBOND POLYESTER
- MINERAL REFLEX WHITE FLEXTER TESTUDO FR TRIARMATO

The second is the FIRE RESISTANCE version, which is resistant to fire from outside and classified as compliant with EN 13501-5 in classes: B_{roof} (t1), B_{roof} (t3), B_{roof} (t4).

STANDARD VAPOUR BARRIER AND BONDING WITH MOLTEN OXIDISED BITUMEN OF HEAT-RESISTANT INSULATING PANELS OR THERMOBASE PUR OR THERMOBASE FR PANELS

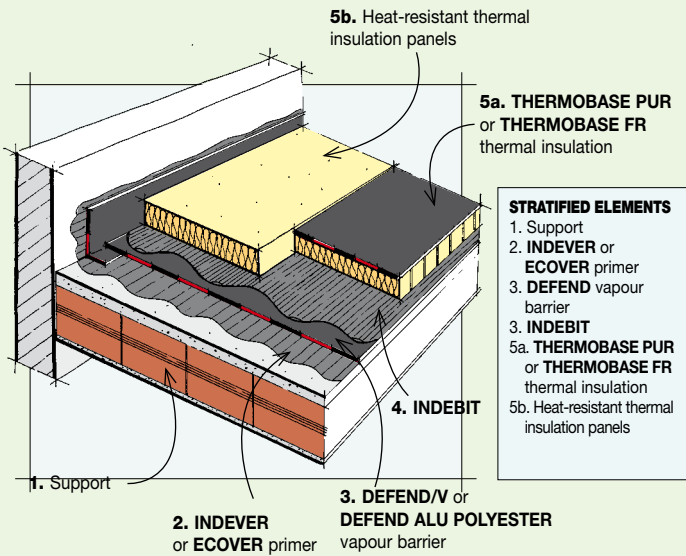

DOUBLE-SIDED ADHESIVE VAPOUR BARRIER AND COLD-BONDING OF EXPANDED POLYSTYRENE OR POLYURETHANE, THERMOBASE PSE, THERMOBASE PSE/EX AND THERMOBASE PUR PANELS

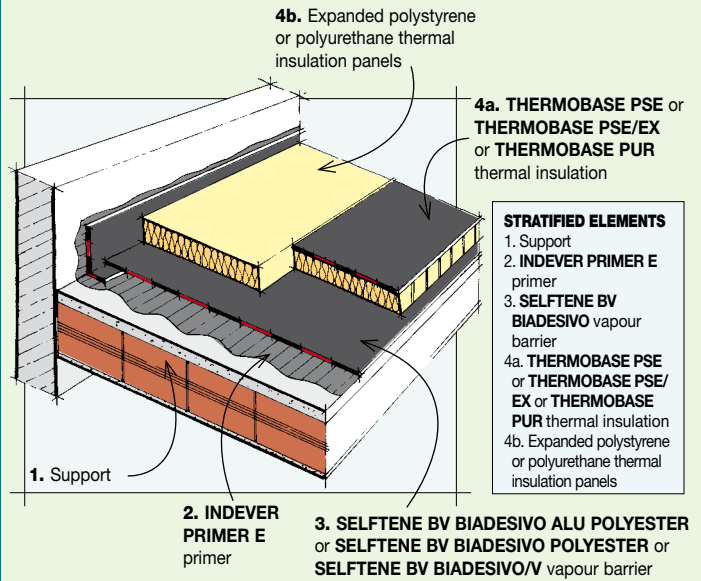

MEMBRANES:

- DEFEND/V
- DEFEND ALU POLYESTER



Reinforced elastoplastomeric polymer-bitumen vapour barrier membranes, resistant and impermeable to gases and water vapour, to be chosen according to the vapour permeability (lower for the ALU POLYESTER version).

• Application method on concrete laying surface

Primer. The entire surface to be coated and the vertical parts onto which the waterproof covering must be bonded, are painted with a coat of about 300 g/m² of INDEVER adhesion bituminous primer, or alternatively ECOVER water-based primer.

Vapour barrier. The vapour barrier sheets are overlapped longitudinally by about 6 cm, whereas the end overlap is about 10 cm.

The sheets of DEFEND/V are stuck to the laying surface in total adhesion using a propane gas torch, whereas DEFEND ALU POLYESTER is spot-bonded using the same technique.

The bonding of the overlaps of both types is also carried out using a torch. The continuity of the vapour barrier on the vertical parts is carried out by heat bonding, onto the edge of the bottom of the projecting parts, a band of membrane wide enough to cover the flat part by at least 10 cm and be turned up vertically by 5 cm more than the thickness of the envisaged insulation.

To fix the insulation panels or rolls of THERMOBASE PUR or THERMOBASE FR insulation onto the vapour barrier, the insulating elements are heat-bonded with oxidised bitumen such as molten INDEBIT at a temperature of no more than 220°C, using 1.5÷2 kg/m². (For the purpose heat-resistant panels are chosen using appropriately trained labour).

Then the overlaps of the membrane coupled with THERMOBASE are heat-bonded.

The connections to the vertical parts are turned up and heat-bonded by at least 20 cm onto the maximum water level and are made up of bands of a polymer-bitumen waterproofing membrane reinforced with spunbond non-woven polyester fabric, stabilised with fibreglass, that is certified with the Agrément I.T.C., such as FLEXTER TESTUDO SPUNBOND POLYESTER 4 mm thick.

MEMBRANES:

- SELFTENE BV BIADESIVO ALU POLYESTER
- SELFTENE BV BIADESIVO POLYESTER
- SELFTENE BV BIADESIVO/V



Reinforced elastomeric polymer-bitumen vapour barrier membranes, double-sided adhesive, multi-functional, resistant, elastic, impermeable to gases and water vapour, to be chosen according to the vapour permeability (lower for the POLYESTER ALU version) or the mechanical resistance (higher for POLYESTER).

The adhesive faces on both sides create the dual function of vapour barrier below the thermal insulation panels, to protect them from the humidity generated inside the building, and adhesive layer, for gluing them onto the roof.

These are products to be laid cold, which meet the specifications of *sustainable building* as by eliminating the melting pot for the oxidised bitumen, the risks of burns are also eliminated, the laying operations on the roof are reduced and therefore also the emission of fumes, smells and noise.

• Application method on concrete laying surface

Finishing the laying surface. To allow complete adhesion of the self-adhesive membranes special care must be taken with the smoothing and flatness of the laying surface.

Primer. The entire surface to be coated and the vertical parts onto which the waterproof covering must be bonded, are painted with a coat of about 350-500 g/m² of INDEVER PRIMER E adhesion bituminous primer.

Vapour barrier. Once you have aligned and overlapped the sheets along the special longitudinal overlap strip on the top face, remove the silicone-coated film on the bottom face of the membrane and glue in place.

The end overlap is approximately 10 cm and is sealed by simple cold pressure, likewise for the longitudinal overlaps.

The membrane is turned up on the vertical parts by 5 cm more than the thickness of the envisaged insulation.

The rows of sheets are arranged in such a way as to offset the end overlaps to prevent 4 sheets crossing.

Adhesion to the laying surface is consolidated by pressing evenly using a metal roller, with particular care on the sheet overlaps.

To stick the insulation panels onto the vapour barrier, remove the silicone-coated film also from the top face and, to prevent the adhesive face from getting dirty and the operator from getting stuck on the glue, just remove the film gradually while sticking the panels in place. Adhesion is consolidated by pressing the adhesive surface of the panel carefully.

VAPOUR BARRIER WITH INCORPORATED HOT-MELT ADHESIVE FOR THE ADHESION OF THE LAYER OF THERMAL INSULATION AND HEAT BONDING OF EXPANDED POLYSTYRENE OR POLYURETHANE, THERMOBASE PSE, THERMOBASE PSE/EX AND THERMOBASE PUR PANELS

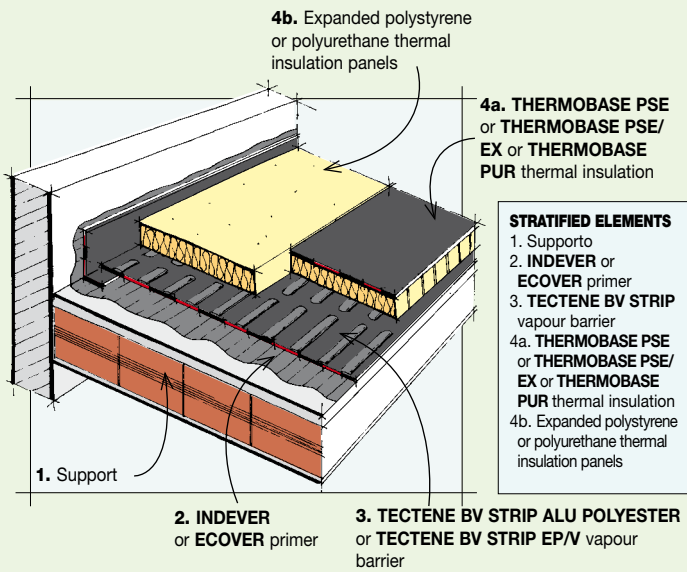

VAPOUR BARRIER WITH INCORPORATED HOT-MELT ADHESIVE FOR THE ADHESION OF THE LAYER OF THERMAL INSULATION AND HEAT-BONDING OF HEAT-RESISTANT INSULATING PANELS OR THERMOBASE PUR PANELS

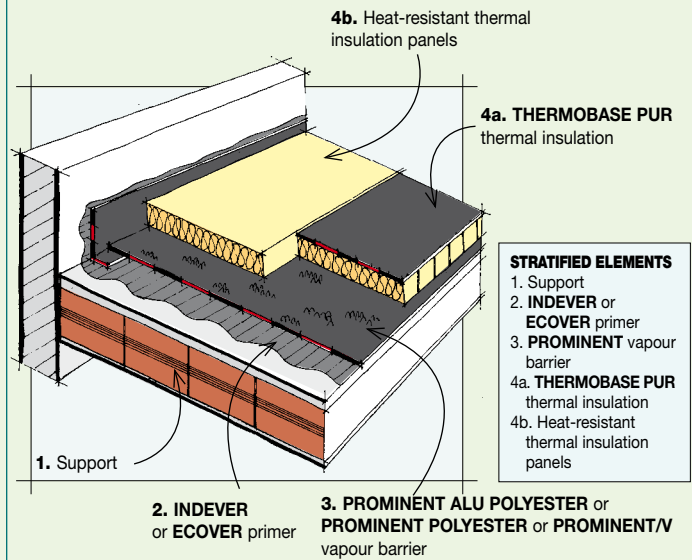

MEMBRANES:

- TECTENE BV STRIP ALU POLYESTER
- TECTENE BV STRIP EP/V



Reinforced elastoplastomeric polymer-bitumen vapour barrier membranes, with the upper face covered in heat-adhesive strips for heat bonding to the insulating panels, resistant and impermeable to gases and water vapour, to be chosen according to the vapour permeability (lower for the ALU POLYESTER version).

These are products to be heat-bonded, which meet the specifications of *sustainable building* as by eliminating the melting pot for the oxidised bitumen, the risks of burns are notably reduced, the laying operations on the roof are reduced and therefore also the emission of fumes, smells and noise.

• Application method on concrete laying surface

Primer. The entire surface to be coated and the vertical parts onto which the waterproof covering must be bonded, are painted with a coat of about 300 g/m² of INDEVER adhesion bituminous primer, or alternatively ECOVER water-based primer.

Vapour barrier. The vapour barrier sheets are overlapped longitudinally by about 6 cm along the selvages with reduced thickness, especially provided on the edge of the sheet in order to allow overlapping without any protruding parts and to obtain a sufficiently flat laying surface for the insulating panels. The end overlap should be about 10 cm.

The sheets of TECTENE BV STRIP are stuck to the laying surface in total adhesion with a propane gas torch and the bonding of the overlaps is also performed using a torch.

The continuity of the vapour barrier on the vertical parts is carried out by heat bonding, onto the edge of the bottom of the projecting parts, a band of elastoplastomeric polymer-bitumen membrane reinforced with composite non-woven polyester fabric coupled to aluminium foil, such as DEFEND ALU POLYESTER, in the event of laying STRIP EP ALU POLYESTER, or reinforced with a fibreglass mat such as DEFEND/V, in the event of laying STRIP EP/V, wide enough to cover the flat part by at least 10 cm and be turned up vertically by 5 cm more than the thickness of the envisaged insulation.

For sticking the insulating panels or THERMOBASE rolls of insulation onto the vapour barrier, the heat-adhesive strips must be heated with a propane gas torch which covers their upper face activating adhesion, and the insulating layer that is pressed on top sticks to it perfectly.

For expanded polystyrene, to prevent melting, the torching must be carried out by appropriately trained staff.

MEMBRANES:

- PROMINENT ALU POLYESTER
- PROMINENT POLYESTER
- PROMINENT/V



Reinforced elastoplastomeric polymer-bitumen vapour barrier membranes, with the upper face covered in heat-adhesive embossings for heat-bonding to the insulating panels, resistant and impermeable to gases and water vapour, to be chosen according to the vapour permeability (lower for the ALU POLYESTER version) or the mechanical resistance (higher for POLYESTER).

These are products to be heat-bonded, which meet the specifications of *sustainable building* as by eliminating the melting pot for the oxidised bitumen, the risks of burns are notably reduced, the laying operations on the roof are reduced and therefore also the emission of fumes, smells and noise.

• Application method on concrete laying surface

Primer. The entire surface to be coated and the vertical parts onto which the waterproof covering must be bonded, are painted with a coat of about 300 g/m² of INDEVER adhesion bituminous primer, or alternatively ECOVER water-based primer.

Vapour barrier. The vapour barrier sheets are overlapped longitudinally by about 6 cm along the two selvages with reduced thickness, especially provided on the edges of the sheet in order to allow overlapping without any protruding parts and to obtain a sufficiently flat laying surface for the insulating panels, whereas the tops of the sheets are laid opposite each other and heat-bonded onto the faces of DEFEND or DEFEND ALU POLYESTER 3 mm thick and 14 cm wide, which have been previously stuck onto the laying surface.

The sheets of PROMINENT are stuck to the laying surface in total adhesion with a propane gas torch and the bonding of the overlaps of both types is also performed using a torch.

The continuity of the vapour barrier on the vertical parts is carried out by heat-bonding, onto the edge of the bottom of the projecting parts, a band of elastoplastomeric polymer-bitumen membrane reinforced with composite polyester non-woven fabric coupled to aluminium foil, like DEFEND ALU POLYESTER, wide enough to cover the flat part by at least 10 cm and be turned up vertically by 5 cm more than the thickness of the envisaged insulation.

For sticking the heat-resistant insulating panels or THERMOBASE PUR rolls of insulation onto the vapour barrier, the heat-adhesive embossings, which cover their upper face, must be heated with a propane gas torch, activating adhesion and the insulating layer that is pressed on top sticks to them perfectly.

DRAINING VAPOUR BARRIER FOR THE DIFFUSION OF CONDENSATION AND THE CONNECTION TO THE SUPPORT IN SEMI-ADHESION

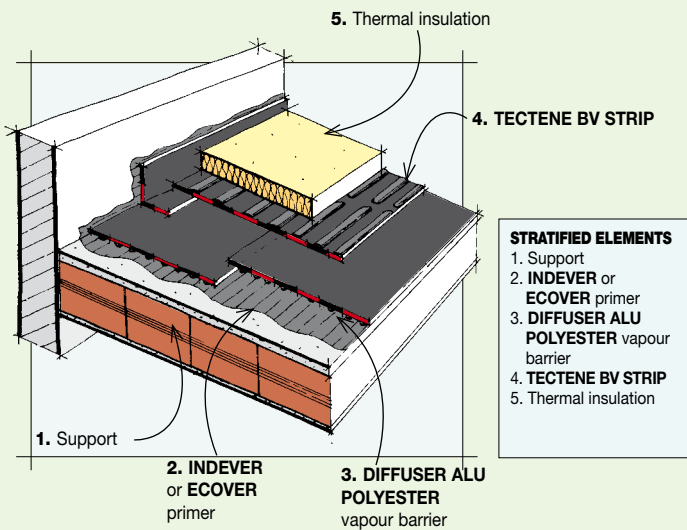

MEMBRANE:
• **DIFFUSER ALU POLYESTER**



Membrane with composite reinforcement in polyester coupled to aluminium foil to be used as a vapour barrier on roofs of rooms with very high humidity to prevent the formation of condensation behind the vapour barrier. The lower face is covered with very thick heat-adhesive embossings for heat bonding with partial adhesion onto about 40% of the laying surface creating, at the same time, a micro air space to allow diffusion of the water vapour. If this is then connected to a suction hood, such as FUGATOR, as indicated in the technical details, the excess vapour can be discharged to the outside.

• **Application method on concrete laying surface**

Primer. The entire surface to be coated and the vertical parts onto which the waterproof covering must be bonded, are painted with a coat of about 300 g/m² of INDEVER adhesion bituminous primer, or alternatively ECOVER water-based primer.

Vapour barrier. The vapour barrier sheets are overlapped longitudinally along the special selvage on the edge of the sheet and are stuck to the laying surface through heat bonding the heat-adhesive embossings that cover the lower face using a propane gas torch.

The lateral overlaps are heat-bonded, whereas in the transversal direction the sheets are butted and not overlapped and the continuity is created by heat bonding a strip of DEFEND ALU POLYESTER 14 cm thick across the joining line.

The sheets on the flat part are stopped at the bottom of the protruding parts and the connection to the vertical parts and roof accessories is created by heat bonding strips of membrane, such as DEFEND ALU POLYESTER with a total width that covers at least 10 cm of the flat part and turned up vertically by 5 cm more than the thickness of the envisaged insulation. Along the perimeter of the roof, a strip at least 1 m wide must be heat bonded with particular care in order to protect the stratified elements from the suction force of the wind.

Subsequently in order to allow adhesion of the bitumen spread for sticking down the insulating panels, the vapour barrier, DEFEND/V, type “**case A**” is laid which is heat-bonded with total adhesion onto the layer of DIFFUSER ALU POLYESTER; if you prefer to fix the insulation through heat bonding to the barrier, type “**case E**” and “**case F**”, the membrane TECTENE BV STRIP/V or PROMINENT/V can be stuck with total adhesion onto DIFFUSER ALU POLYESTER.

THERMAL INSULATION AND FIRST LAYER OF THE WATERPROOF COVERING WITH

- THERMOBASE PSE/120
- THERMOBASE PSE/EX

Thermal insulators in boards coupled to waterproofing membranes supplied in rolls.

The thickness of the insulation must be sufficiently high to prevent the dew point dropping below the vapour barrier and must comply with legislation in force on energy containment in buildings.

• **Application method on TECTENE BV STRIP**

By heating the heat-adhesive strips that cover the upper face of the vapour barrier using a propane gas torch, the adhesion is activated, and the roll of THERMOBASE insulation pressed on top sticks to it perfectly. Then the overlaps and connections to the vertical parts are turned up and heat-bonded by at least 20 cm onto the maximum water level and are made up of bands of a polymer-bitumen waterproofing membrane reinforced with spunbond non-woven polyester fabric, stabilised with fibreglass, that is certified with the Agrément I.T.C. such as FLEXTER TESTUDO SPUNBOND POLYESTER 4 mm thick.

The torching of the heat-adhesive strips and the bonding of the overlap of the elements must be carried out by appropriately trained staff and must take place with necessary caution in order to prevent the expanded polystyrene melting.

• **Application method on SELFTENE BV BIADESIVO**

To stick the insulation panels onto the vapour barrier, remove the silicone-coated film also from the top face of SELFTENE BIADESIVO and, to prevent the adhesive face from getting dirty and the operator from getting stuck on the glue, just remove the film gradually while unrolling the rolls of THERMOBASE. Adhesion is consolidated by pressing the adhesive surface of the insulation carefully.

Then the overlaps and connections to the vertical parts are turned up and heat-bonded by at least 20 cm onto the maximum water level and are made up of bands of a polymer-bitumen waterproofing membrane reinforced with spunbond non-woven polyester fabric, stabilised with fibreglass, that is certified with the Agrément I.T.C. such as FLEXTER TESTUDO SPUNBOND POLYESTER 4 mm thick.

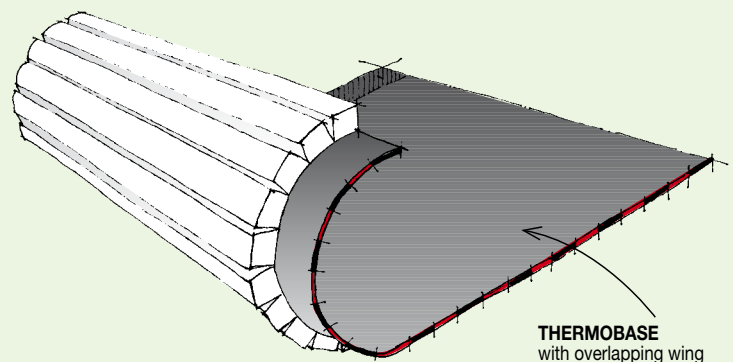

Note.

THERMAL INSULATION AND FIRST LAYER OF THE WATERPROOF COVERING WITH

- THERMOBASE FR

On roofs with a visible covering, insulating panels with poor cohesion and THERMOBASE FR cannot be cold-bonded onto self-adhesive membranes, or heat-bonded onto the membranes TECTENE BV STRIP or PROMINENT and are only stuck by spreading molten oxidised bitumen or through mechanical fixing, which is not covered in this technical document.

THERMAL INSULATION AND FIRST LAYER OF THE WATERPROOF COVERING WITH
• THERMOBASE PUR

Thermal insulators in boards coupled to waterproofing membranes supplied in rolls.

The thickness of the insulation must be sufficiently high to prevent the dew point dropping below the vapour barrier and must comply with legislation in force on energy containment in buildings.

• Application method on TECTENE BV STRIP or PROMINENT

By torching the embossings or heat-adhesive strips that cover the upper face of the vapour barrier using a propane torch, the adhesion is activated, and the roll of THERMOBASE insulation pressed on top sticks to it perfectly. Then the overlaps and connections to the vertical parts are turned up and heat-bonded by at least 20 cm onto the maximum water level and are made up of bands of a polymer-bitumen waterproofing membrane reinforced with spunbond non-woven polyester fabric, stabilised with fibreglass, that is certified with the Agrément I.T.C. such as FLEXTER TESTUDO SPUNBOND POLYESTER 4 mm thick.

• Application method on SELFTENE BV BIADESIVO

To stick the insulation panels onto the vapour barrier, remove the silicone-coated film also from the top face of SELFTENE BIADESIVO and, to prevent the adhesive face from getting dirty and the operator from getting stuck on the glue, just remove the film gradually while unrolling the rolls of THERMOBASE. Adhesion is consolidated by pressing the adhesive surface of the insulation carefully. Then the overlaps and connections to the vertical parts are turned up and heat-bonded by at least 20 cm onto the maximum water level and are made up of bands of a polymer-bitumen waterproofing membrane reinforced with spunbond non-woven polyester fabric, stabilised with fibreglass, that is certified with the Agrément I.T.C. such as FLEXTER TESTUDO SPUNBOND POLYESTER 4 mm thick.

LAYING THERMOBASE ON MULTIFUNCTIONAL VAPOUR BARRIERS



SELFTENE BV BIADESIVO



Self-adhesive mixture



PROMINENT



Heat-adhesive embossings

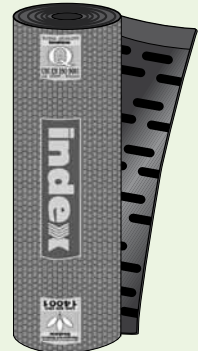

TECTENE BV STRIP



Heat-adhesive strips



Advantages of the system:

- Fire risk from the hot bitumen melting pot is eliminated
- No more burns
- No more fumes
- No more smells
- It can also be stuck safely on slopes

SINGLE-LAYER WATERPROOF COVERING ON CONCRETE LAYING SURFACE

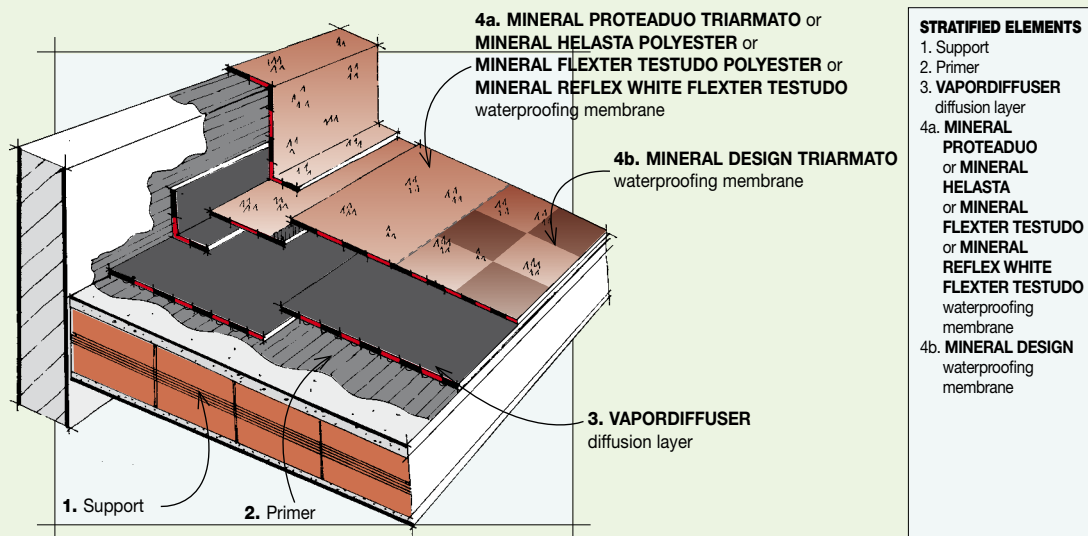

• **Laying method**

Primer. The vertical parts onto which the waterproof covering must be stuck, are painted with a coat of about 300 g/m² of INDEVER adhesion bituminous primer, or alternatively ECOVER water-based primer.

Diffusion layer. To prevent the formation of bubbles due to trapped humidity in damp concrete supports, which is transformed into vapour, and commonly occurs in coverings stuck with total adhesion when they are exposed to the sun, the vapour diffusion membrane VAPORDIFFUSER/V reinforced with a fibreglass mat is heat-bonded onto the concrete surface painted with primer. The lower face is covered with very thick heat-adhesive embossings for heat bonding with partial adhesion onto about 40% of the laying surface creating, at the same time, a micro air space to allow diffusion of the water vapour. If this is then connected to a suction hood, such as FUGATOR, as indicated in the technical details, the excess vapour can be discharged to the outside. The sheets are overlapped longitudinally along the special selvage on the edge of the sheet and are stuck to the laying surface through heat bonding the heat-adhesive embossings that cover the lower face using a propane gas torch.

The lateral overlaps are heat-bonded, whereas in the transversal direction the sheets are butted and not overlapped and the continuity is created by heat bonding a strip of DEFEND/V 14 cm thick across the joining line.

The sheets on the flat part are stopped at the bottom of the protruding parts and the connection to the vertical parts and roof accessories is created by heat bonding strips of the same type of membrane chosen for the waterproof covering.

Along the perimeter of the roof, a strip at least 1m wide must be heat bonded with particular care in order to protect the stratified elements from the suction force of the wind.

Later the waterproof covering is stuck onto the diffusion layer.

Single-layer waterproof covering.

• **Single-layer waterproof covering with MINERAL PROTEADUO TRIARMATO multi-layer composite membrane.** A multi-layer composite elastomeric and elastoplastomeric polymer-bitumen waterproofing membrane, self-protected with slate granules, 4 mm thick, with prefabricated stabilised three-layer composite reinforcement consisting of a fibreglass mat between two spunbond “non-woven” polyester fabrics, such as MINERAL PROTEADUO TRIARMATO, is stuck onto the diffusion layer with complete heat-bonded adhesion.

Or alternatively:

• **Single-layer waterproof covering with MINERAL HELASTA POLYESTER elastomeric membrane.** An elastomeric polymer-bitumen waterproofing membrane, self-protected with slate granules, 4 mm thick, with a distilled bitumen and radial butadiene-styrene thermoplastic rubber base, reinforced with spunbond “non-woven” polyester fabric, such as MINERAL HELASTA POLYESTER is stuck onto the diffusion layer with complete heat-bonded adhesion.

Or alternatively:

• **Single-layer waterproof covering with MINERAL FLEXTER TESTUDO SPUNBOND POLYESTER elastoplastomeric membrane.** An elastoplastomeric polymer-bitumen waterproofing membrane, self-protected with slate granules, 4 mm thick, with a distilled bitumen, plastomer and elastomer base, with composite reinforcement in spunbond “non woven” polyester fabric stabilised with fibreglass, such as MINERAL FLEXTER TESTUDO SPUNBOND POLYESTER 4, is stuck onto the diffusion layer, with complete heat-bonded adhesion..

Or alternatively:

• **Single-layer waterproof covering with MINERAL REFLEX WHITE FLEXTER TESTUDO SPUNBOND POLYESTER elastoplastomeric membrane.** An elastoplastomeric polymer-bitumen waterproofing membrane, such as MINERAL REFLEX WHITE FLEXTER TESTUDO SPUNBOND POLYESTER 4, is laid onto the diffusion layer, with complete heat-bonded adhesion. It has special high saturation and luminosity white mineral self-protection for energy saving and the reduction of “urban heat islands” with high solar reflectance and very high thermal emissivity, 4 mm thick, with a distilled bitumen, plastomer and elastomer base, with composite reinforcement in spunbond “non woven” POLYESTER fabric stabilised with fibreglass.

Or alternatively:

• **Single-layer waterproof covering with MINERAL DESIGN TRIARMATO elastoplastomeric membrane.** A multifunctional elastoplastomeric polymer-bitumen membrane, self-protected with a combination of ceramic-coated mineral granules, in different types of patterns, for the decoration and development of the design of roofs with visible coverings, with prefabricated stabilised three-layer composite reinforcement consisting of a fibreglass mat between two spunbond “non-woven” polyester fabrics, such as MINERAL DESIGN TRIARMATO SPUNBOND POLYESTER, is stuck onto the diffusion layer with complete heat-bonded adhesion.

The membrane sheets, arranged across the overlaps of the diffusion layer, are overlapped by 10 cm in the longitudinal direction along the special overlapping strip without slate and by 15 cm in the transversal direction, and are heat-bonded across the whole surface and onto the overlaps using a propane gas torch. The waterproof covering is turned up and stuck with complete heat-bonded adhesion onto the vertical parts by at least 20 cm above the water flowing surface.

DOUBLE-LAYER WATERPROOF COVERING ON THERMOBASE THERMAL INSULATION

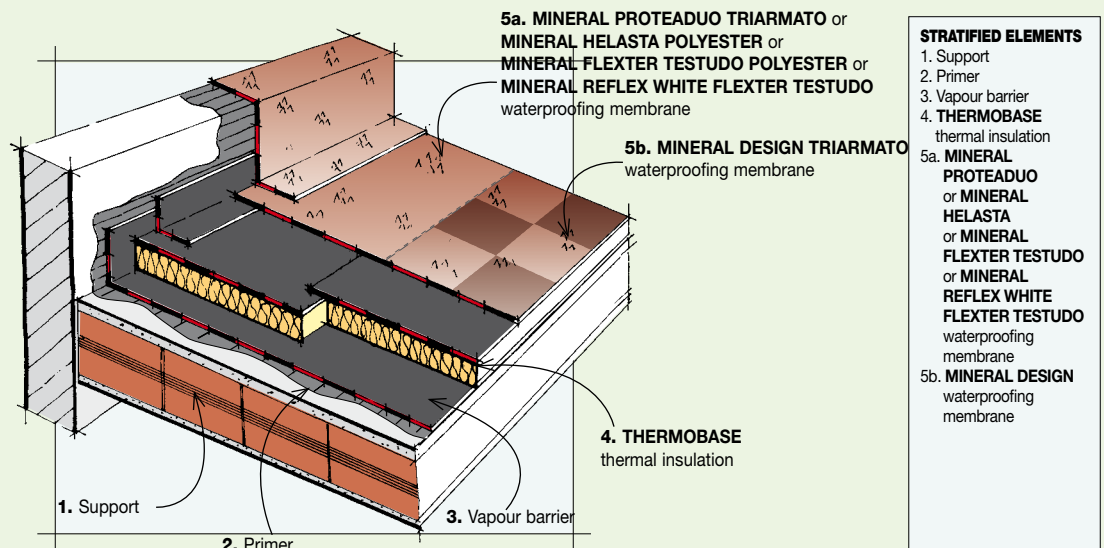

THERMOBASE is coupled on the upper face with an underlayer membrane reinforced with polyester non-woven fabric. Therefore, laying just one top membrane layer will be sufficient to obtain a double-layer covering.

• **Laying method**

• **Upper layer with MINERAL PROTEADUO TRIARMATO multi-layer composite membrane.** A multi-layer composite elastomeric and elastoplastomeric polymer-bitumen waterproofing membrane, self-protected with slate granules, 4 mm thick, with pre-fabricated stabilised three-layer composite reinforcement consisting of a fibreglass mat between two spunbond “non-woven” polyester fabrics, such as MINERAL PROTEADUO TRIARMATO is stuck onto the layer of THERMOBASE with complete heat-bonded adhesion.

Or alternatively:

• **Upper layer with MINERAL HELASTA POLYESTER elastomeric membrane.** An elastomeric polymer-bitumen waterproofing membrane, self-protected with slate granules, 4 mm thick, with a distilled bitumen and radial butadiene-styrene thermoplastic rubber base, reinforced with spunbond polyester “non-woven” fabric, such as MINERAL HELASTA POLYESTER is stuck onto the layer of THERMOBASE with complete heat-bonded adhesion.

Or alternatively:

• **Upper layer with MINERAL FLEXTER TESTUDO SPUNBOND POLYESTER elastoplastomeric membrane.** An elastoplastomeric polymer-bitumen waterproofing membrane, self-protected with slate granules, 4 mm thick, with a distilled bitumen, plastomer and elastomer base, with composite reinforcement in spunbond “non woven” polyester fabric stabilised with fibreglass, such as MINERAL FLEXTER TESTUDO SPUNBOND POLYESTER 4, is stuck onto the layer of THERMOBASE, with complete heat-bonded adhesion.

Or alternatively:

• **Upper layer with MINERAL REFLEX WHITE FLEXTER TESTUDO SPUNBOND POLYESTER elastoplastomeric membrane.** An elastoplastomeric polymer-bitumen waterproofing membrane, such as MINERAL REFLEX WHITE FLEXTER TESTUDO SPUNBOND POLYESTER 4, is laid onto the diffusion layer, with complete heat-bonded adhesion. It has special high saturation and luminosity white mineral self-protection for energy saving and the reduction of “urban heat islands” with high solar reflectance and very high thermal emissivity, 4 mm thick, with a distilled bitumen, plastomer and elastomer base, with composite reinforcement in spunbond “non woven” POLYESTER fabric stabilised with fibreglass.

Or alternatively:

• **Upper layer with MINERAL DESIGN TRIARMATO elastoplastomeric membrane.** A multifunctional elastoplastomeric polymer-bitumen membrane, self-protected with a combination of ceramic-coated mineral granules, in different types of patterns, for the decoration and development of the design of roofs with visible coverings, with prefabricated stabilised three-layer composite reinforcement consisting of a fibreglass mat between two spunbond “non-woven” polyester fabrics, such as MINERAL DESIGN TRIARMATO SPUNBOND POLYESTER, is stuck onto the layer of THERMOBASE with complete heat-bonded adhesion.

The membrane sheets on the upper layer, arranged across the overlaps of the underlayer membrane of THERMOBASE, are overlapped by 10 cm in the longitudinal direction along the special overlapping strip without slate and by 15 cm in the transversal direction, and are heat-bonded across the whole surface and onto the overlaps using a propane gas torch. The waterproof covering is turned up and stuck with total adhesion on the vertical parts by at least 20 cm above the water flowing surface.

DOUBLE-LAYER WATERPROOF COVERING ON LAYER OF HEAT-RESISTANT THERMAL INSULATION

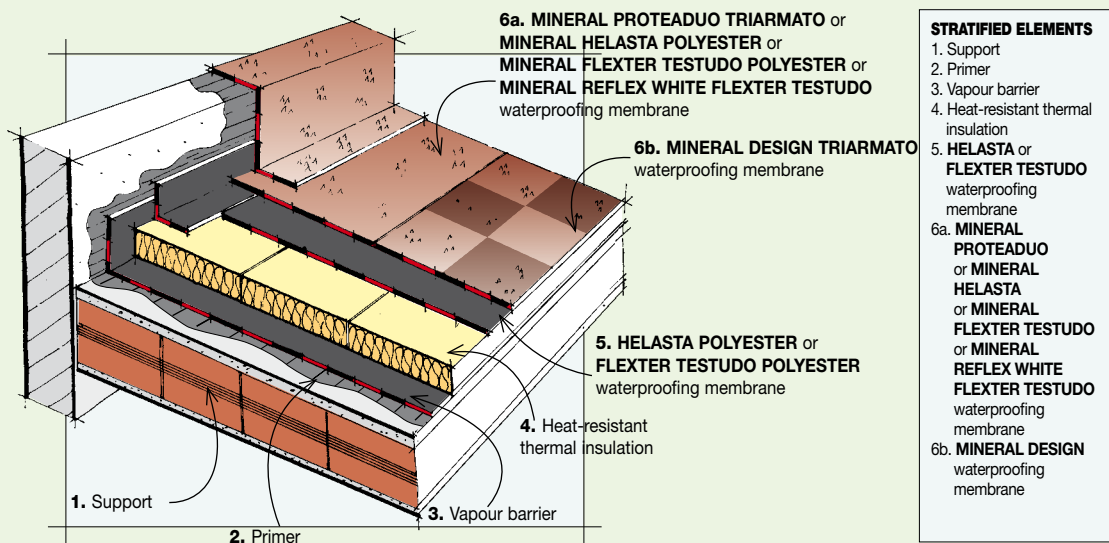

• Laying method

• Double-layer waterproof covering with elastomeric membrane and multi-layer composite membrane made up of HELASTA POLYESTER + MINERAL PROTEADUO TRIARMATO.

- **Underlayer membrane:** An elastomeric polymer-bitumen waterproofing membrane, 4 cm thick, with a distilled bitumen and radial butadiene-styrene thermoplastic rubber base, reinforced with spunbond “non-woven” polyester fabric, such as HELASTA POLYESTER 4 is stuck onto the layer of thermal insulation in panels with complete heat-bonded adhesion. The sheets are laid dry onto the laying surface and overlapped with 10 cm in the longitudinal direction and 15 cm in the transversal direction; the overlaps are heat-bonded with a propane gas torch. The waterproof covering is turned up and stuck with complete heat-bonded adhesion onto the vertical parts.

- **Upperlayer membrane:** The upper layer of the waterproof covering is made up of a multi-layer composite elastomeric and elastoplastomeric polymer-bitumen waterproofing membrane, self-protected with slate granules, 4 mm thick, with pre-fabricated stabilised three-layer composite reinforcement consisting of a fibre-glass mat between two spunbond non-woven polyester fabrics, such as MINERAL PROTEADUO TRIARMATO. The sheets on the second layer overlapping by 10 cm longitudinally and 15 cm transversally, are arranged across the overlaps of the first layer and heat-bonded onto the whole surface and the overlaps. The waterproof covering is turned up on the vertical parts by at least 20 cm above the water flowing surface.

Or alternatively:

• Double-layer waterproof covering with HELASTA POLYESTER + MINERAL HELASTA

- **Underlayer membrane:** An elastomeric polymer-bitumen waterproofing membrane, 4 cm thick, with a distilled bitumen and radial butadiene-styrene thermoplastic rubber base, reinforced with spunbond non-woven polyester fabric, such as HELASTA POLYESTER 4 is stuck onto the layer of thermal insulation in panels with complete heat-bonded adhesion. The sheets are laid dry onto the laying surface and overlapped with 10 cm in the longitudinal direction and 15 cm in the transversal direction; the overlaps are heat-bonded with a propane gas torch. The waterproof covering is turned up and stuck with complete heat-bonded adhesion onto the vertical parts.

- **Upperlayer membrane:** The upper layer of the waterproofing covering is made up of an elastomeric polymer-bitumen waterproofing membrane, self-protected with slate granules, 4 mm thick, with a distilled bitumen and radial butadiene-styrene thermoplastic rubber base, reinforced with spunbond “non-woven” polyester fabric, such as MINERAL HELASTA POLYESTER. The sheets on the second layer overlapping by 10 cm longitudinally and 15 cm transversally, are arranged across the overlaps of the first layer and heat-bonded onto the whole surface and the overlaps. The waterproof covering is turned up on the vertical parts by at least 20 cm above the water flowing surface.

Or alternatively:

• Waterproof double-layer covering with FLEXTER TESTUDO SPUNBOND POLYESTER + MINERAL FLEXTER TESTUDO SPUNBOND POLYESTER elastoplastomeric membrane.

- **Underlayer membrane:** An elastoplastomeric polymer-bitumen waterproofing membrane, 4 mm thick, with a distilled bitumen, plastomer and elastomer base, with composite reinforcement in spunbond “non-woven” polyester fabric stabilised with fibreglass, FLEXTER TESTUDO SPUNBOND POLYESTER 4, is stuck onto the layer of thermal insulation in panels with complete heat-bonded adhesion. The sheets overlap by 10 cm in the longitudinal direction and by 15 cm in the transversal direction; the overlaps are heat-bonded with a propane gas torch. The waterproof covering is turned up and stuck with complete heat-bonded adhesion onto the vertical parts.

- **Upper layer with MINERAL REFLEX WHITE FLEXTER TESTUDO SPUNBOND POLYESTER elastoplastomeric membrane:** The upper layer of the waterproof covering is made up of an elastoplastomeric polymer-bitumen waterproofing membrane, self-protected with slate granules, 4 mm thick, with a distilled bitumen, plastomer and elastomer base, with composite reinforcement in spunbond “non woven” polyester fabric stabilised with fibreglass, such as MINERAL FLEXTER TESTUDO SPUNBOND POLYESTER 4.

The sheets on the second layer overlapping by 10 cm longitudinally and 15 cm transversally, are arranged across the overlaps of the first layer and heat-bonded onto the whole surface and the overlaps. The waterproof covering is turned up on the vertical parts by at least 20 cm above the water flowing surface.

Or alternatively **upper layer with MINERAL REFLEX WHITE FLEXTER TESTUDO SPUNBOND POLYESTER elastoplastomeric membrane.**

- **Upperlayer membrane:** The upper layer of the waterproof covering is made up of an elastoplastomeric polymer-bitumen waterproofing membrane, such as MINERAL REFLEX WHITE FLEXTER TESTUDO SPUNBOND POLISTERE 4. It has special high saturation and luminosity white mineral self-protection for energy saving and the reduction of “urban heat islands” with high solar reflectance and very high thermal emissivity, 4 mm thick, with a distilled bitumen, plastomer and elastomer base, with composite reinforcement in spunbond “non woven” POLYESTER fabric stabilised with fibreglass.

Or alternatively **upper layer with MINERAL DESIGN TRIARMATO elastoplastomeric membrane.**

- **Upperlayer membrane:** The upper layer of the waterproof covering is made up of a multifunctional elastoplastomeric polymer-bitumen waterproofing membrane, self-protected with a combination of ceramic-coated mineral granules, in different types of patterns, for the decoration and development of the design of roofs with visible coverings, with prefabricated stabilised three-layer composite reinforcement consisting of a fibre-glass mat between two spunbond polyester “non-woven” fabrics, such as MINERAL DESIGN TRIARMATO.

The sheets on the second layer overlapping by 10 cm longitudinally and 15 cm transversally, are arranged across the overlaps of the first layer and heat-bonded onto the whole surface and the overlaps. The waterproof covering is turned up on the vertical parts by at least 20 cm above the water flowing surface.

DOUBLE-LAYER WATERPROOF COVERING ON NON-HEAT-RESISTANT THERMAL INSULATION WITH SELF-HEAT-ADHESIVE UNDERLAYER MEMBRANE

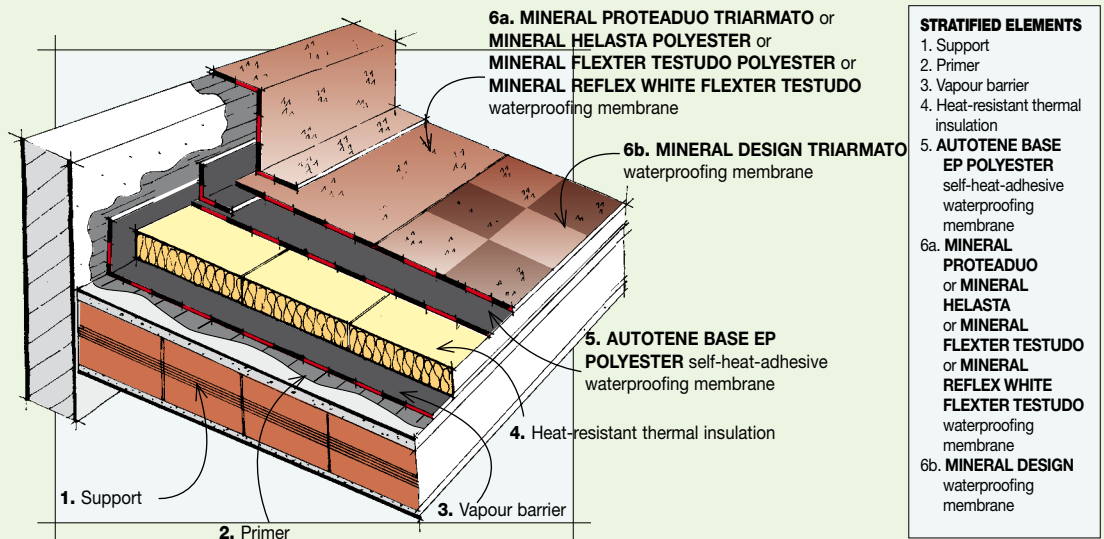

For heat bonding the membranes onto heat-sensitive insulating materials (expanded polystyrene either extruded or sintered) they must first be protected. To stick the membranes to the expanded polystyrene, either extruded or sintered, a special self-heat-adhesive substrate of AUTOTENE BASE EP POLYESTER must be used, which is applied dry onto the insulation and subsequently adheres on its own due to the heat produced by the heat-bonding of the upper layer that is stuck on top.

• Laying method

Protection layer and substrate. The substrate of the two-layer waterproof covering is laid dry onto insulating panels with longitudinal overlaps of 6 cm and transversal overlaps of 10 cm. It is made up of a self-heat-adhesive waterproofing base membrane, such as AUTOTENE BASE EP POLYESTER in elastoplastomeric polymer-bitumen, 3 mm thick, with the lower face and overlapping strip of the upper face coated with an adhesive mixture activated by the indirect heat generated by the heat bonding of the next layer. Both self-heat-adhesive surfaces are protected by a silicone-coated film which is removed as the rolls used to cover the whole flat surface are unrolled and stopped at the bottom of the vertical parts. The vertical parts are covered with a strip of smooth membrane of the same type as that used for the upper layer.

• Upper layer with MINERAL PROTEADUO TRIARMATO multi-layer composite membrane. A multi-layer composite elastomeric and elastoplastomeric polymer-bitumen waterproofing membrane, self-protected with slate granules, 4 mm thick, with prefabricated stabilised three-layer composite reinforcement consisting of a fibreglass mat between two spunbond non-woven polyester fabrics, such as MINERAL PROTEADUO TRIARMATO is stuck onto the diffusion layer with complete heat-bonded adhesion.

Or alternatively:

• Upper layer with MINERAL HELASTA POLYESTER elastomeric membrane. An elastomeric polymer-bitumen waterproofing membrane, self-protected with slate granules, 4 mm thick, with a distilled bitumen and radial butadiene-styrene thermoplastic rubber base, reinforced with spunbond non-woven polyester fabric, such as MINERAL HELASTA POLYESTER is stuck onto the diffusion layer with total adhesion.

Or alternatively:

• Upper layer with MINERAL FLEXTER TESTUDO SPUNBOND POLYESTER elastoplastomeric membrane. An elastoplastomeric polymer-bitumen waterproofing membrane, self-protected with slate granules, 4 mm thick, with a distilled bitumen, plastomer and elastomer base, with composite reinforcement in spunbond non woven polyester fabric stabilised with fibreglass, such as MINERAL FLEXTER TESTUDO SPUNBOND POLYESTER 4, is stuck onto the diffusion layer, with complete heat-bonded adhesion.

Or alternatively:

• Upper layer with MINERAL REFLEX WHITE FLEXTER TESTUDO SPUNBOND POLYESTER elastoplastomeric membrane. An elastoplastomeric polymer-bitumen waterproofing membrane, such as MINERAL REFLEX WHITE FLEXTER TESTUDO SPUNBOND POLIESTERE 4, is laid onto the protection layer, with complete heat-bonded adhesion. It has special high saturation and luminosity white mineral self-protection for energy saving and the reduction of “urban heat islands” with high solar reflectance and very high thermal emissivity, 4 mm thick, with a distilled bitumen, plastomer and elastomer base, with composite reinforcement in spunbond “non woven” polyester fabric stabilised with fibreglass.

Or alternatively:

• Upper layer with MINERAL DESIGN TRIARMATO elastoplastomeric membrane. A multifunctional elastoplastomeric polymer-bitumen membrane, self-protected with a combination of ceramic-coated mineral granules, in different types of patterns, for the decoration and development of the design of roofs with visible coverings, with prefabricated stabilised three-layer composite reinforcement consisting of a fibreglass mat between two spunbond non-woven polyester fabrics, such as MINERAL DESIGN TRIARMATO SPUNBOND POLYESTER, is stuck onto the diffusion layer with complete heat-bonded adhesion.

The membrane sheets on the upper layer, arranged across the overlaps of the underlayer membrane, are overlapped by 10 cm in the longitudinal direction along the special overlapping strip without slate and by 15 cm in the transversal direction, and are heat-bonded across the whole surface and onto the overlaps using a propane gas torch. The heat generated by the heat bonding of the second layer causes the complete adhesion of the self-heat-adhesive substrate onto the layer of thermal insulation at the same time, without causing it to melt. The waterproof covering is turned up and stuck onto the vertical parts by at least 20 cm above the water flowing surface.

INVERTED ROOF WITH SINGLE-LAYER WATERPROOF COVERING UNDER EXTRUDED POLYSTYRENE WEIGHED DOWN WITH GRAVEL

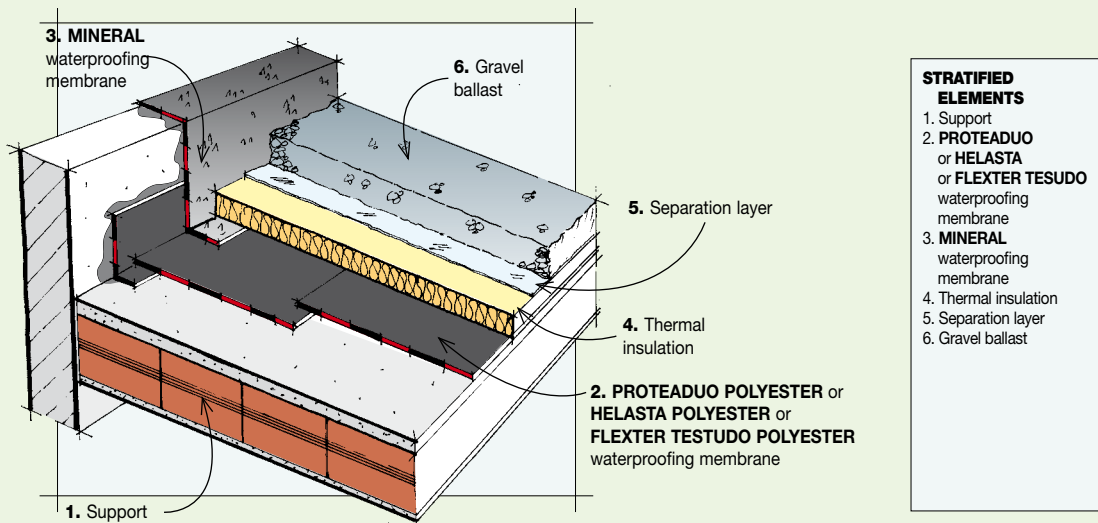

• **Laying method**

Primer. The vertical parts onto which the waterproof covering must be stuck, are painted with a coat of about 300 g/m² of INDEVER adhesion bituminous primer, or alternatively ECOVER water-based primer.

Single-layer waterproof covering. A polymer-bitumen waterproofing membrane, 4 mm thick, chosen from the types listed below, is laid with low adhesion onto the laying surface.

The sheets are laid dry onto the laying surface overlapping by 10 cm in the longitudinal direction and by 15 cm in the transversal direction; the overlaps are heat-bonded using a propane gas torch.

The turn-up of the waterproof covering on the vertical parts exposed to the sun's rays is protected by a layer of polymer-bitumen waterproofing membrane, self-protected with slate granules, 4 mm thick, of the same type as that used for the flat surface of the roof, which is turned up and heat-bonded with complete adhesion onto the protruding parts by at least 20 cm above the water flowing surface.

• **Single-layer waterproof covering with PROTEADUO TRIARMATO multi-layer composite membrane.** A multi-layer elastoplastic and elastomeric polymer-bitumen composite waterproofing membrane, 4 mm thick, with prefabricated stabilised three-layer composite reinforcement consisting of a fibreglass mat between two spunbond non-woven polyester fabrics, such as PROTEADUO TRIARMATO is laid dry onto the concrete laying surface, whereas the covering of the vertical parts without protection is performed with the self-protected version with slate granules of the same membrane, such as MINERAL PROTEADUO TRIARMATO.

Or alternatively:

• **Single-layer waterproof covering with HELASTA POLYESTER elastomeric membrane.** An elastomeric polymer-bitumen waterproofing membrane, self-protected with slate granules, 4 mm thick, reinforced with spunbond non-woven polyester fabric, such as HELASTA POLYESTER is laid dry onto the concrete laying surface, whereas the covering of the vertical parts without protection is performed with the self-protected version with slate granules of the same membrane, such as MINERAL HELASTA POLYESTER.

Or alternatively:

• **Single-layer waterproof covering with FLEXTER TESTUDO SPUNBOND POLYESTER elastoplastic membrane.** An elastoplastic polymer-bitumen waterproofing membrane, 4 mm thick, with composite reinforcement in spunbond polyester non-woven fabric, stabilised with fibreglass, such as FLEXTER TESTUDO SPUNBOND POLYESTER 4 is laid dry onto the concrete laying surface, whereas the covering of the vertical parts without protection is performed with the self-protected version with slate granules of the same membrane, such as MINERAL FLEXTER TESTUDO SPUNBOND POLYESTER.

LAYING DETAILS

Connection methods of the membrane to the laying surface

COMPLETE ADHESION APPLICATION

The torching of the mixture of the rolls must affect the membrane and the support at the same time, concentrating on the roll. The torch flame must also be directed onto the membrane already laid for overlapping.

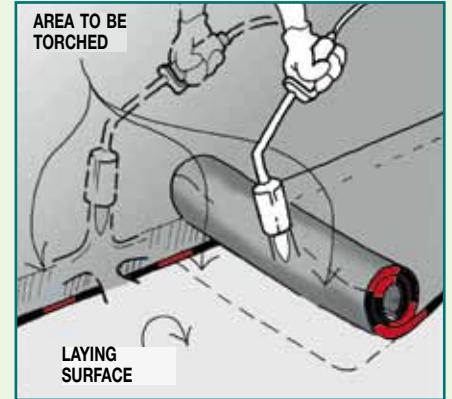

SEMI-ADHESION APPLICATION

VAPORDIFFUSER/V and DIFFUSER ALU are membranes whose lower face is covered with heat-adhesive embossings sticking out from the sheet which, when heated with a torch, become adhesive and allow partial adhesion to be performed on about 40% of the laying surface by means of "bitumen nails", and the creation of a micro air space, between the laying surface and the membrane, which can diffuse water vapour.

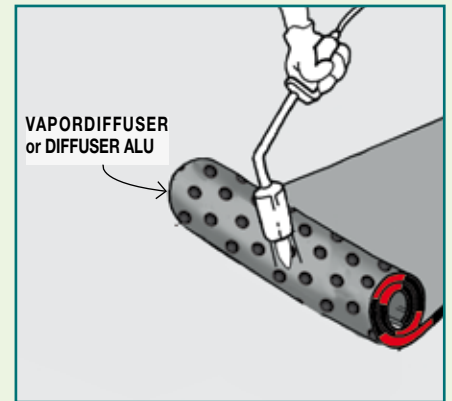

Preparing the laying surface

On the suitably clean and wet slab, a sloping screed (1-5%) is created with good adhesion and smoothed with a trowel, made up of concrete prepared with 200-250 kg Portland cement (325 grade) per m³ of mixture; for the areas where a thickness of less than 3 cm is envisaged, the screed is made from mortar prepared with 350 kg of cement per m³ of sand. The screed can be made of concrete with light mineral granules prepared with 250 kg of Portland cement per m³ of mixture.

The sloping screed may also be made of cellular concrete or light concrete with non-mineral granules as long as they are sufficiently cohesive to allow adhesion to the membranes. On roofs made of prefabricated reinforced concrete panels across the joining lines of the tiles, bands of 20 cm wide FLEXTER TESTUDO SPUNBOND POLYESTER 4 are heat-bonded either before laying the sloping screed or the waterproof covering or vapour barrier placed straight onto the prefabricated panels.

The laying surface must be smooth and flat. A concrete surface is defined as such if below a 2 m rule placed in all directions no gaps of over 10 mm appear, and under a 0.20 m rule, gaps of over 3 mm. The surface must be smoothed with a trowel and any cracks or dips must be filled in with mortar. Any roughness must be removed, as must any remains from building work, such as nails, metal sheets, wood, etc. Before application, the laying surface must be clean and dry; for concrete and cement and brick laying surfaces it is best to wait for a drying period of 8 days to 3 weeks according to the season.

Preparing the protruding parts

At the bottom of all the protruding parts, external walls, brick chimneys and the parts sticking out from the roof, the special vertical housing is created for the waterproofing, min. 4 cm deep and 10 cm above the max. ground level and with the bottom covered in rough plaster.

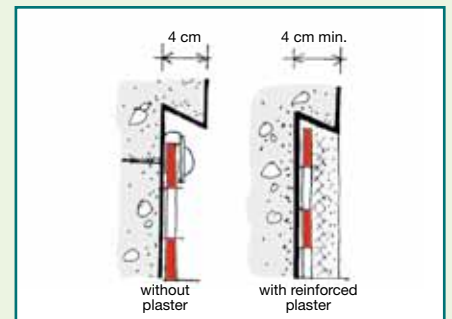

Preparing the cast protruding parts

The vertical housing of the waterproofing is created by inserting a wooden board, 4 cm thick and 10 cm higher than the max. level of the floor, in the formworks before casting, which is removed after the concrete has hardened.

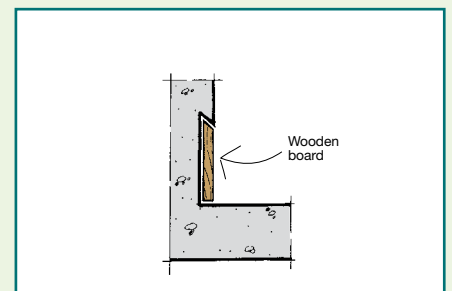

Protruding parts with weather moulding

If it is not possible to create the vertical housing in the wall, the head of the waterproof covering is protected by a structural metal weather moulding fixed mechanically to the protruding part and sealed at the top.

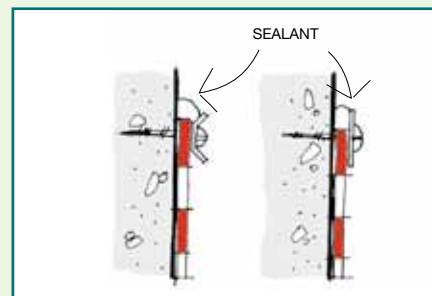

Drainpipes

Around the drain hole a housing is created 10 cm wider than the pipe connector and 1-1.5 cm deep; for a terrace with thermal insulation this housing will be created in the insulation. Each drain must serve a maximum surface area of 500 m², must have a hole with a diameter suitable for the surface area and the stormwater must only travel a maximum distance of 30 m to reach the drain.

With a max. flow rate of 3 l/m per m²:

Minimum diameter of discharge hole	Affected area
6 cm	28 m ²
8 cm	50 m ²
10 cm	80 m ²
12 cm	110 m ²
14 cm	150 m ²
16 cm	200 m ²
18 cm	250 m ²
20 cm	300 m ²
22 cm	380 m ²
25 cm	490 m ²

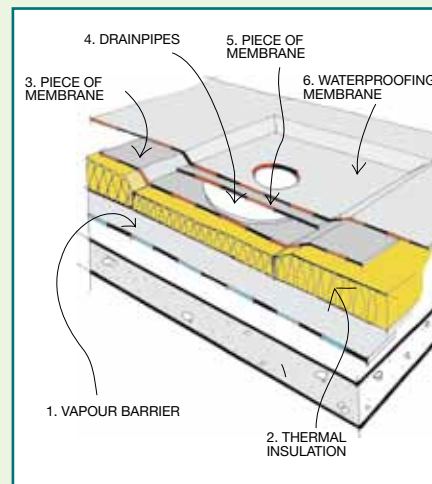

Overflow pipes

An overflow pipe is envisaged for terraces with only one drain, should the water not be able to flow out due to a blocked drain or in the event that the water overload due to the blocked drains compromises the roof's stability.

It is made up of a circular or rectangular conduit with the same cross-section as the drainpipe and provided with a connector to the waterproof covering; it is placed on the external part of the terrace at an intermediate level between the floor and the lowest part of the waterproof protruding parts.

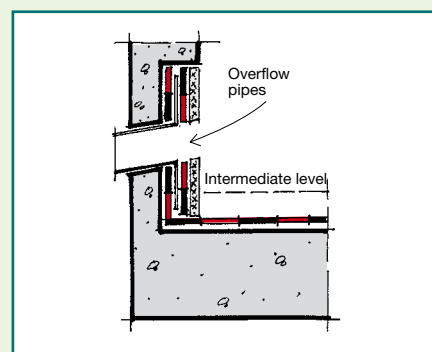

Threshold

The height of the access threshold to the terrace must be such that the waterproof covering lies across it by at least 10 cm above the ground level.

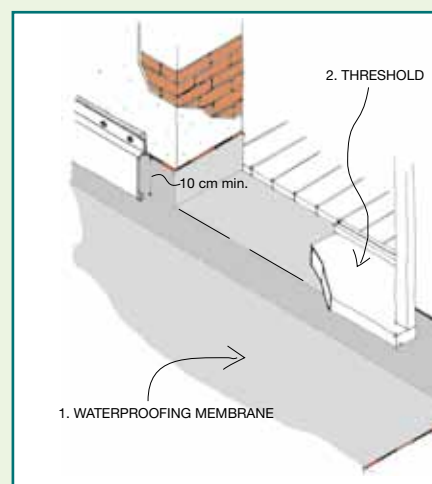

Protruding piping

For metal, PVC or reinforced concrete pipes or insufficiently thick chimneys, a wall 10 cm above the ground level must be built around them, onto which the waterproof covering will be laid and protected by a metal weather moulding integral with the piping.

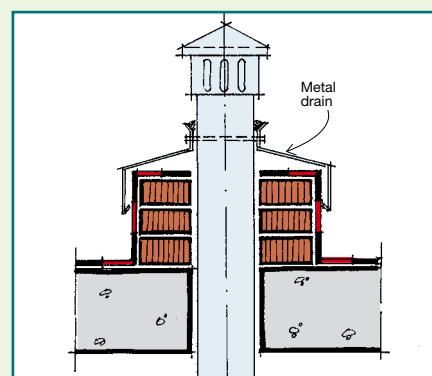

Preparing a joint next to a wall

Any cracks in joints are filled with compressible insulating material.

Along the edge of the joint a wall is built 10 cm higher than ground level and about 15 cm wide, in which the housing for the waterproof covering will be created, as for the protruding parts. The waterproof protection of the joint is ensured using a metal sheet integral with the highest wall, to cover the entire wall.

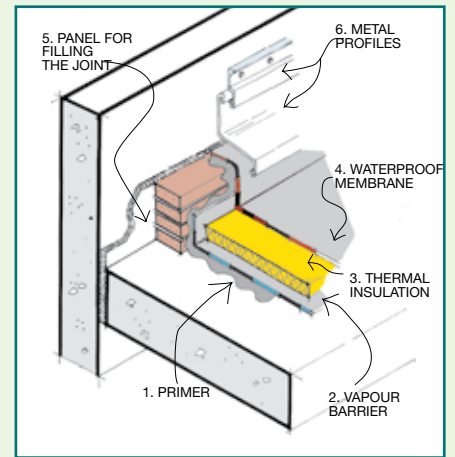

Waterproof covering of protruding parts, walls and vertical parts in general

All the vertical parts that the covering must lie across are painted with a coat of INDEVER or ECOVER bituminous primer.

A 20 cm high strip of membrane is heat-bonded across the corner created by the vertical part and the THERMOBASE panel.

Then the waterproof sheet on the flat part is overlapped and stuck into the horizontal piece of the strip, whereas a second strip doubles the protection of the protruding part and the corner.

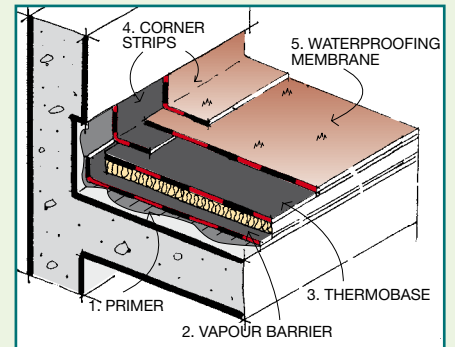

Waterproof covering of flat expansion joints

The vapour barrier is stuck onto the walls next to the joint up to 5 cm from the edge of the gap.

Across the joint, a sheet of HELASTA POLYESTER 33 cm high is laid, which forms an omega shape in the gap. The wings of the sheet are heat-bonded onto the vapour barrier.

The waterproof sheet of the flat part is heat-bonded onto the wings of the HELASTA POLYESTER up to 5 cm from the edge of the joint.

The omega shape of HELASTA POLYESTER is filled with a string-course of compressible material (e.g. expanded polyethylene, fibre-glass plait, etc.) of a sufficient diameter to completely fill the crack and it is all protected by a sheet of HELASTA POLYESTER 33 cm high, heat-bonded across the joint.

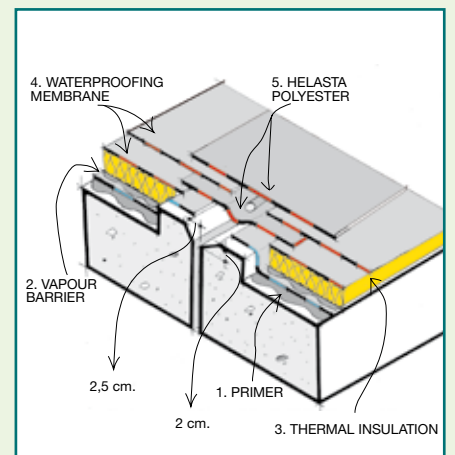

Waterproof covering of drainpipes

The drainpipe housing is painted with a coat of INDEVER and a piece of DEFEND of the same size is heat bonded onto it.

The drainpipe connector is then stuck onto the sheet tempered with the torch.

Then the waterproof covering is bonded onto the piece fixed to the laying surface and onto the pipe connector.

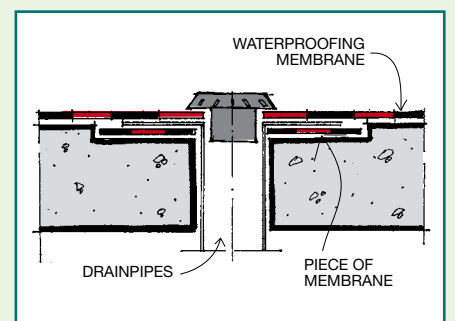

TECHNICAL SPECIFICATIONS

PRIMER

INDEVER

Quick drying adhesion bituminous primer suitable for preparing surfaces for the heat bonding of polymer-bitumen membranes, such as INDEVER, with a base of oxidised bitumen, additives and solvents with solid content of 50% and cup viscosity DIN/4 at 20°C (UNI EN ISO 2431) of 12÷17 s.

INDEVER PRIMER E

Quick drying solvent-based elastomeric adhesion bituminous primer suitable for preparing surfaces both for the heat bonding of standard polymer-bitumen membranes and for cold laying of self-adhesive and self-heat-adhesive polymer bitumen membranes such as INDEVER PRIMER E.

The primer will have a solid content of (UNI 8911) of 50% and cup viscosity DIN/4 at 20°C (UNI EN ISO 2431) of 20÷25 s.

ECOVER

Adhesion bituminous primer, suitable for preparing surfaces for the heat bonding of polymer-bitumen membranes, such as ECOVER, with a water bituminous emulsion base, with solid content (UNI EN ISO 3251) of 37%.

COMPLEMENTARY PRODUCTS

VAPORDIFFUSER/V

Elastoplastomeric polymer-bitumen vapour barrier membrane, of 4 kg/m² (EN1849-1), able to create a micro air space on the surface to which it is stuck for draining water vapour and connection in semi-adhesion with "bitumen nails" onto about 40% of the surface, obtained by torching the heat-adhesive embossings that protrude by about 3.5 mm from its lower face. The membrane reinforced with a rot-proof fibreglass mat has a resistance to tearing (EN 12311-1) L/T of 70/70 N, tensile strength L/T. (EN 12311-1) of 300/200 N/50 mm and ultimate elongation L/T. (EN 12311-1) of 2/2 %.

VAPOUR BARRIER

STANDARD VAPOUR BARRIER MEMBRANES

DEFEND ALU POLYESTER

Elastoplastomeric polymer-bitumen vapour barrier membrane, 3-mm thick (EN1849-1), reinforced with aluminium foil coupled to a non-woven composite polyester fabric stabilised with fibreglass, with water vapour permeability (EN 1931) $\mu=1,500,000$, tensile strength (EN 12311-1) L/T of 250/120 N/50 mm and ultimate elongation (EN 12311-1) L/T of 15/20%.

DEFEND/V

Elastoplastomeric polymer-bitumen vapour barrier membrane, 3-mm thick (EN1849-1), reinforced with fibreglass mat, with water vapour permeability (EN 1931) $\mu=100,000$, tensile strength (EN 12311-1) L/T of 300/200 N/50 mm and ultimate elongation (EN 12311-1) L/T of 2/2%.

INNOVATIVE VAPOUR BARRIER MEMBRANES WITH INCORPORATED ADHESIVE FOR COLD-BONDING OF THE THERMAL INSULATION

SELFENE BV BIADESIVO ALU POLYESTER

Double-sided adhesive elastomeric polymer-bitumen vapour barrier membrane of 3 kg/m² (EN1849-1), reinforced with aluminium foil, coupled to a non-woven composite polyester fabric stabilised with fibreglass, with water vapour permeability (EN 1931) $\mu=1,500,000$, tensile strength (EN 12311-1) L/T of 250/120 N/50 mm and ultimate elongation (EN 12311-1) L/T of 15/20%.

SELFENE BV BIADESIVO POLYESTER

Double-sided adhesive elastomeric polymer-bitumen vapour barrier membrane of 3 kg/m² (EN1849-1), reinforced with non-woven composite polyester fabric stabilised with fibreglass, with water vapour permeability (EN 1931) $\mu=100,000$, tensile strength (EN 12311-1) L/T of 400/300 N/50 mm and ultimate elongation (EN 12311-1) L/T of 40/40%.

SELFENE BV BIADESIVO ALU POLYESTER

Double-sided adhesive elastomeric polymer-bitumen vapour barrier membrane of 3 kg/m² (EN1849-1), reinforced with fibreglass mat, with water vapour permeability (EN 1931) $\mu=100,000$, tensile strength (EN 12311-1) L/T of 300/200 N/50 mm and ultimate elongation (EN 12311-1) L/T of 2/2%.

INNOVATIVE VAPOUR BARRIER MEMBRANES WITH INCORPORATED HEAT ACTIVATED ADHESIVE FOR STICKING NON-HEAT-RESISTANT THERMAL INSULATION

TECTENE BV STRIP ALU POLYESTER

Elastoplastomeric polymer-bitumen vapour barrier membrane with incorporated adhesive for sticking insulating panels, made up of heat-adhesive strips distributed across 40% of the upper face of the sheet, 3 mm thick (EN1849-1) reinforced with aluminium foil coupled to a non-woven composite polyester fabric stabilised with fibreglass, with water vapour permeability (EN 1931) $\mu=1,500,000$, tensile strength (EN 12311-1) L/T of 250/120 N/50 mm and ultimate elongation (EN 12311-1) L/T of 15/20%.

TECTENE BV STRIP EP/V

Elastoplastomeric polymer-bitumen vapour barrier membrane with incorporated adhesive for sticking insulating panels, made up of heat-adhesive strips distributed across 40% of the upper face of the sheet, 3 mm thick (EN1849-1), reinforced with fibreglass mat, with water vapour permeability (EN 1931) $\mu=100,000$, tensile strength (EN 12311-1) L/T of 300/200 N/50 mm and ultimate elongation (EN 12311-1) L/T of 2/2%.

VAPOUR BARRIER

INNOVATIVE VAPOUR BARRIER MEMBRANES WITH INCORPORATED HEAT ACTIVATED ADHESIVE FOR STICKING HEAT-RESISTANT THERMAL INSULATION

PROMINENT ALU POLYESTER

Elastoplastomeric polymer-bitumen vapour barrier membrane of 4 kg/m² (EN1849-1), with incorporated adhesive for sticking insulating panels, made up of heat-adhesive embossings, 5 mm thick, distributed across 40% of the upper face of the sheet, reinforced with aluminium foil coupled to a non-woven composite polyester fabric stabilised with fibreglass, with water vapour permeability (EN 1931) $\mu=1,500,000$, tensile strength (EN 12311-1) L/T of 250/120 N/50 mm and ultimate elongation (EN 12311-1) L/T of 15/20%.

PROMINENT POLYESTER

Elastoplastomeric polymer-bitumen vapour barrier membrane of 4 kg/m² (EN1849-1), with incorporated adhesive for sticking insulating panels, made up of heat-adhesive embossings, 5 mm thick, distributed across 40% of the upper face of the sheet, reinforced with non-woven composite polyester fabric stabilised with fibreglass, with water vapour permeability (EN 1931) $\mu=100,000$, tensile strength (EN 12311-1) L/T of 450/400 N/50 mm and ultimate elongation (EN 12311-1) L/T of 40/40%.

PROMINENT/V

Elastoplastomeric polymer-bitumen vapour barrier membrane of 4 kg/m² (EN1849-1), with incorporated adhesive for sticking insulating panels, made up of heat-adhesive embossings, 5 mm thick, distributed across 40% of the upper face of the sheet, reinforced with fibreglass mat, with water vapour permeability (EN 1931) $\mu=100,000$, tensile strength (EN 12311-1) L/T of 300/200 N/50 mm and ultimate elongation (EN 12311-1) L/T of 2/2%.

INNOVATIVE DRAINING VAPOUR BARRIERS FOR THE DIFFUSION OF CONDENSATION AND THE CONNECTION TO THE SUPPORT WITH SEMI-ADHESION

DIFFUSER ALU POLYESTER

Elastoplastomeric polymer-bitumen vapour barrier membrane, of 4 kg/m² (EN1849-1), able to create a micro air space on the surface to which it is stuck for draining water vapour and connection in semi-adhesion with "bitumen nails" onto about 40% of the surface, obtained by torching the heat-adhesive embossings that protrude by about 3.5 mm from its lower face.

The membrane reinforced with aluminium foil, coupled to a non-woven composite polyester fabric stabilised with fibreglass, has water vapour permeability (EN 1931) $\mu=1,500,000$, tensile strength (EN 12311-1) L/T of 250/120 N/50 mm and ultimate elongation (EN 12311-1) L/T of 15/20%.

THERMAL INSULATION

INSULATORS PRE-COUPLED WITH MEMBRANES

THERMOBASE PSE/120

Thermal insulation supplied in rolls with overlapping selvage such as THERMOBASE PSE/120 made up of insulating strips 5 cm wide and 100 cm long in sintered expanded polystyrene with a compression resistance of 10% (EN 826) ≥ 120 KPa [CS(10)120] heat-bonded continuously to a polymer-bitumen membrane P4 110 cm wide to allow the elements to be overlapped longitudinally.

The membrane is reinforced with non-woven composite polyester fabric stabilised with fibreglass and has a hot stability (EN 1110) of 120°C, flexibility (EN 1109) of -15°C, ultimate tensile strength (EN 12311-1) L/T of 600/400 N/5 cm and ultimate elongation (EN 12311-1) L/T of 40/40%.

THERMOBASE PSE/EX

Thermal insulation supplied in rolls with overlapping selvage such as THERMOBASE PSE/EX made up of insulating strips 5 cm wide and 100 cm long in extruded expanded polystyrene with a 10% compression resistance (EN 826) ≥ 200 KPa [CS(10/Y)200] heat-bonded continuously to a polymer-bitumen membrane P4 110 cm wide to allow the elements to be overlapped longitudinally.

The membrane is reinforced with non-woven composite polyester fabric stabilised with fibreglass and has a hot stability (EN 1110) of 120°C, flexibility (EN 1109) of -15°C, ultimate tensile strength (EN 12311-1) L/T of 600/400 N/5 cm and ultimate elongation (EN 12311-1) L/T of 40/40%.

THERMOBASE PSE PUR

Thermal insulation supplied in rolls with overlapping selvage such as THERMOBASE PUR made up of 5 cm wide and 100 cm long insulating strips of expanded polyurethane rolled continuously between two fibreglass mats or two bituminised foam boards which are continuously heat-bonded to a polymer-bitumen membrane P4 110 cm wide to allow the longitudinal overlap of the elements, with a 10% compression resistance (EN 826) ≥ 100 KPa [CS(10/Y)100].

The membrane is reinforced with non-woven composite polyester fabric stabilised with fibreglass and has a hot stability (EN 1110) of 120°C, flexibility (EN 1109) of -15°C, ultimate tensile strength (EN 12311-1) L/T of 600/400 N/5 cm and ultimate elongation (EN 12311-1) L/T of 40/40%.

THERMOBASE FR/100

Thermal insulation supplied in rolls with overlapping selvage such as THERMOBASE FR/100 made up of insulating strips 5 cm wide and 100 cm long in oriented rock fibre which are heat-bonded continuously to a polymer-bitumen membrane P4 110 cm wide to allow the elements to be overlapped longitudinally, with a compression resistance of 10% (EN 826) ≥ 60 KPa [CS(10)60].

The membrane is reinforced with non-woven composite polyester fabric stabilised with fibreglass and has a hot stability (EN 1110) of 120°C, flexibility (EN 1109) of -15°C, ultimate tensile strength (EN 12311-1) L/T of 600/400 N/5 cm and ultimate elongation (EN 12311-1) L/T of 40/40%.

WATERPROOF LAYER

AUTOTENE BASE EP POLYESTER

Self-heat-adhesive waterproofing base membrane, such as AUTOTENE BASE EP POLYESTER, in elastoplastomeric polymer bitumen, 3 mm thick (EN 1849-1), with the bottom face and the overlapping strip of the top face coated with an adhesive mix, which is activated by the indirect heat generated by heat bonding the next layer, both protected by a silicone-coated film which is removed as the roll is unrolled. The membrane reinforced with stabilised composite polyester non-woven fabric, has a tensile strength L/T (EN 12311/1) of 450/400 N/50 mm, ultimate elongation (EN 12311-1) L/T of 40/40%, resistance to impact (EN 12691 method A) of 800 mm, resistance to static load (EN 12730) of 10 kg and cold flexibility (EN 1109) of -15°C.

WATERPROOF LAYER

PROTEADUO TRIARMATO

Multi-layer composite polymer-bitumen waterproofing membrane, 4 mm thick, such as PROTEADUO TRIARMATO, certified with the EuroAgrément I.T.C.-CNR (former I.C.I.T.E.), made up of an upper layer in elastoplastomeric polymer bitumen with ring and ball softening point (EN 1427) of 150°C, a lower layer in elastomeric polymer bitumen with elastic recovery (NF XP 84-360) of 300% and a stabilised three-layer composite reinforcement with fibreglass between two spunbond polyester “non-woven fabrics”, impregnated with elastomeric polymer bitumen. The membrane has a tensile strength (EN 12311-1) L/T of 750/650 N/50 mm, ultimate elongation (EN 12311-1) L/T of 50/50%, resistance to tearing (EN 12310-1) L/T of 250/250 N and cold flexibility (EN 1109) of the upper layer of -15°C and of the lower layer of -25°C.

MINERAL PROTEADUO TRIARMATO

Multi-layer composite polymer-bitumen waterproofing membrane, covered with slate granules, 4 mm thick measured on the selvage, such as MINERAL PROTEADUO TRIARMATO, certified with the EuroAgrément I.T.C.-CNR (former I.C.I.T.E.), made up of an upper layer in elastoplastomeric polymer bitumen with ring and ball softening point (EN 1427) of 150°C, a lower layer in elastomeric polymer bitumen with elastic recovery (NF XP 84-360) of 300% and a stabilised three-layer composite reinforcement with fibreglass between two spunbond non-woven polyester fabrics, impregnated with elastomeric polymer bitumen. The membrane has a tensile strength (EN 12311-1) L/T of 750/650 N/50 mm, ultimate elongation (EN 12311-1) L/T of 50/50%, resistance to tearing (EN 12310-1) L/T of 250/250 N and cold flexibility (EN 1109) of the upper layer of -15°C and of the lower layer of -25°C.

HELASTA POLYESTER

Elastomeric polymer-bitumen waterproofing membrane, 4 mm thick, with a radial butadiene-styrene thermoplastic rubber base and distilled bitumen base, with ultimate elongation of 2000% and elastic recovery (NF-XP 84-360) of 300%, reinforced with spunbond polyester non-woven fabric, such as HELASTA POLYESTER 4, certified with the Agrément I.T.C.-CNR (former I.C.I.T.E.). The membrane has a tensile strength (EN 12311-1) L/T of 900/700 N/50mm, ultimate elongation (EN 12311-1) L/T of 50/50 %, resistance to tearing (EN 12310-1) L/T of 200/200 N, fatigue resistance (UEAtc) of over 1,000 cycles on new material and over 500 cycles on artificially aged material, cold flexibility (EN1109) of -25°C and hot stability (EN1110) of 100°C.

MINERAL HELASTA POLYESTER

Elastomeric polymer-bitumen waterproofing membrane, covered with slate granules, 4 mm thick measured on the selvage, with a radial butadiene-styrene thermoplastic rubber base and distilled bitumen base, with ultimate elongation of 2000% and elastic recovery (NF-XP 84-360) of 300%, reinforced with spunbond polyester non-woven fabric, such as MINERAL HELASTA POLYESTER 4, certified with the Agrément I.T.C.-CNR (former I.C.I.T.E.). The membrane has a tensile strength (EN 12311-1) L/T of 900/700 N/50mm, ultimate elongation (EN 12311-1) L/T of 50/50 %, resistance to tearing (EN 12310-1) L/T of 200/200 N, fatigue resistance (UEAtc) of over 1,000 cycles on new material and over 500 cycles on artificially aged material, cold flexibility (EN1109) of -25°C and hot stability (EN1110) of 100°C.

FLEXTER TESTUDO SPUNBOND POLYESTER

Elastoplastomeric polymer-bitumen waterproofing membrane, 4-mm thick, based on distilled bitumen, plastomers and elastomers, with composite reinforcement consisting of spunbond non-woven polyester fabric stabilised with fibreglass, FLEXTER TESTUDO SPUNBOND POLYESTER 4, certified with the Agrément ITC-CNR (former ICITE). The membrane has a tensile strength (EN 12311-1) L/T of 850/700 N/50mm, ultimate elongation (EN 12311-1) L/T of 50/50 %, resistance to tearing (EN 12310-1) L/T of 150/150 N, resistance to impact (EN 12691 - method A) of 1,250 mm, resistance to static load (EN 12730) of 15 kg, hot dimensional stability (EN 1107-1), L/T of $\pm 0,3/\pm 0,3\%$, cold flexibility (EN1109) of -20°C and heat resistance (EN1110) of 140°C.

MINERAL FLEXTER TESTUDO SPUNBOND POLYESTER

Elastoplastomeric polymer-bitumen waterproofing membrane, self-protected with slate granules, 4 mm thick measured on the selvage, based on distilled bitumen, plastomers and elastomers, with composite reinforcement consisting of spunbond non-woven polyester fabric stabilised with fibreglass, MINERAL FLEXTER TESTUDO SPUNBOND POLYESTER 4 type, certified with the Agrément ITC-CNR (former ICITE). The membrane has a tensile strength (EN 12311-1) L/T of 850/700 N/50mm, ultimate elongation (EN 12311-1) L/T of 50/50 %, resistance to tearing (EN 12310-1) L/T of 150/150 N, hot dimensional stability (EN 1107-1), L/T of $\pm 0,3/\pm 0,2\%$, cold flexibility (EN1109) of -20°C and heat resistance (EN1110) of 140°C.

MINERAL REFLEX WHITE FLEXTER TESTUDO SPUNBOND POLYESTER

An elastoplastomeric polymer-bitumen waterproofing membrane, such as MINERAL REFLEX WHITE FLEXTER TESTUDO SPUNBOND POLYESTER 4, with special high saturation and luminosity white mineral self-protection for energy saving and the reduction of “urban heat islands”. It has high solar reflectance and very high thermal emissivity, 4 mm thick measured on the selvage, with a distilled bitumen, plastomer and elastomer base, with composite reinforcement in spunbond “non woven” polyester fabric stabilised with fibreglass, certified with Agrément I.T.C.- CNR (former I.C.I.T.E.).

The membrane, with a Solar Reflectance index according to the wind SRI = 52-54%, has a tensile strength (EN 12311-1) L/T of 850/700 N/50mm, ultimate elongation (EN 12311-1) L/T of 50/50 %, resistance to tearing (EN 12310-1) L/T of 150/150 N, hot dimensional stability (EN 1107-1), L/T of $\pm 0,3/\pm 0,2\%$, cold flexibility (EN1109) of -20°C and heat resistance (EN1110) of 140°C.

Fire-resistant version

MINERAL REFLEX WHITE FLEXTER TESTUDO FR TRIARMATO

Fire Resistance elastoplastomeric polymer-bitumen waterproofing membrane, certified as compliant with EN 13501-5 in classes: Broof (t1), Broof (t3), Broof (t4). It has special high saturation and luminosity white mineral self-protection for energy saving and the reduction of “urban heat islands” with high solar reflectance and very high thermal emissivity, 4 mm thick measured on the selvage, with a distilled bitumen, plastomer and elastomer base, with composite triple reinforcement in spunbond “non woven” polyester fabric stabilised with fibreglass, such as MINERAL REFLEX WHITE FLEXTER TESTUDO FR TRIARMATO 4, certified with Belgian Agrément UBatc ATG 1616.

The membrane, with a Solar Reflectance index according to the wind SRI = 52-54%, has a tensile strength (EN 12311-1) L/T of 750/650 N/50mm, ultimate elongation (EN 12311-1) L/T of 50/50 %, resistance to tearing (EN 12310-1) L/T of 250/250 N, hot dimensional stability (EN 1107-1), L/T of $\pm 0,25/\pm 0,1\%$, cold flexibility (EN1109) of -15°C and heat resistance (EN1110) of 140°C.

WATERPROOF LAYER

MINERAL DESIGN TRIARMATO

Elastoplastomeric polymer bitumen multi-functional waterproofing membrane, with prefabricated stabilised three-layer composite reinforcement consisting of a fibreglass mat between two spunbond non-woven polyester fabrics, such as MINERAL DESIGN TRIARMATO SPUNBOND POLYESTER. Produced in different types of patterns obtained by combining two types of different colours of ceramic-coated mineral granules for the decoration and development of the design of roofs with visible coverings.

The membrane has a mass per unit area (EN 1849-1) of 4.5 kg/m², tensile strength (EN 12311-1) L/T of 750/650 N/50 mm, ultimate elongation (EN 12311-1) L/T of 50/50%, resistance to tearing (EN 12310-1) L/T of 250 N, hot dimensional stability (EN 1107-1) L/T of $\pm 0,2/\pm 0,1\%$, cold flexibility (EN 1109) of -15°C and heat resistance (EN 1110) of 120°C.

Mineral Design decoration table

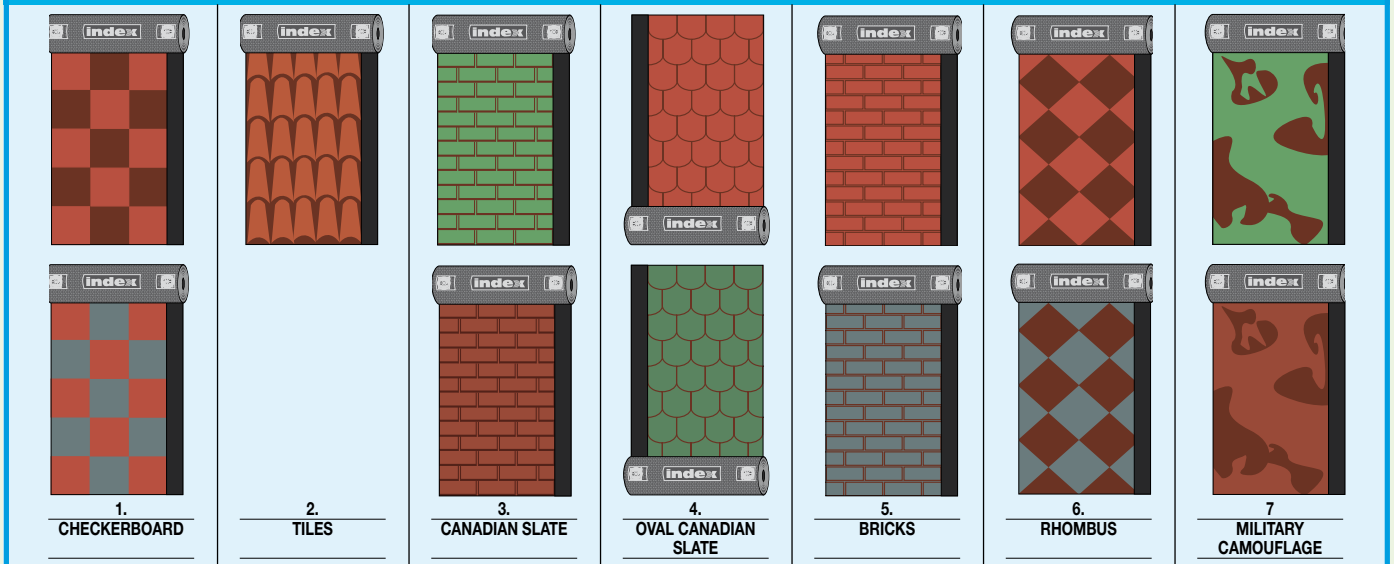

HIGH REFLECTANCE AND HIGH EMISSIVITY PAINT

WHITE REFLEX

One-component white paint, based on polymers in an aqueous emulsion and special additives, flexible, resistant to atmospheric agents, with high solar reflectance and emissivity of infrared rays, able to increase the diffused light and the efficiency of the photovoltaic panels, to reduce the surface temperature of the waterproof covering during the daytime, promote the dissipation of the heat accumulated during the night and consequently produce consistent energy saving from air conditioning buildings. The paint has solar reflectance (ASTM C-1549) > 0.80, infrared emissivity (ASTM C-1471) > 0.85 and a Solar Reflectance Index SRI > 90%.

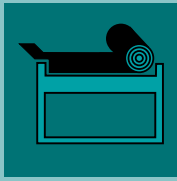

Technical specification

• FOR ANY FURTHER INFORMATION OR ADVICE ON PARTICULAR APPLICATIONS, CONTACT OUR TECHNICAL OFFICE • IN ORDER TO CORRECTLY USE OUR PRODUCTS, REFER TO INDEX TECHNICAL SPECIFICATIONS •

index
Construction Systems and Products

Internet: www.indexspa.it
e-mail Inform. Tecniche Commerciali: tecom@indexspa.it
e-mail Amministrazione e Segreteria: index@indexspa.it
e-mail Index Export Dept.: index.export@indexspa.it

Via G. Rossini, 22 - 37060 Castel D'Azzano (VR) - Italy - C.P.67 - Tel. (+39)045.8546201 - Fax (+39)045.512444



ing the numerous possible uses and the possible interference of conditions or elements beyond our control, we assume no responsibility regarding the results which are obtained. The purchasers, of their own accord and under their own responsibility, must establish the suitability of the product for the envisaged use.

The figures shown are average indicative figures relevant to current production and may be changed or updated by INDEX S.p.A. at any time without previous warning. The advice and technical information provided, is what results from our best knowledge regarding the properties and the use of the product. Consider